

TECHNICAL MANUAL

**OPERATOR'S AND UNIT MAINTENANCE MANUAL
(INCLUDING REPAIR PARTS AND SPECIAL TOOLS LIST)**

**FILTER/SEPARATOR, LIQUID FUEL, TYPE I
FRAME MOUNTED, 50 GPM CAPACITY
(MODEL 011 F-Z-001) NSN 4330-00-250-4381
(MODEL 59FS50ALV) NSN 4330-00-250-4381
(MODEL GFS-4-V50AL) NSN 4330-00-250-4381
AND MODEL 13217E7140 (97403) TYPE II
NON-FRAME MOUNTED 50 GPM FILTER/SEPARATOR
NSN 4330-01-012-3313**

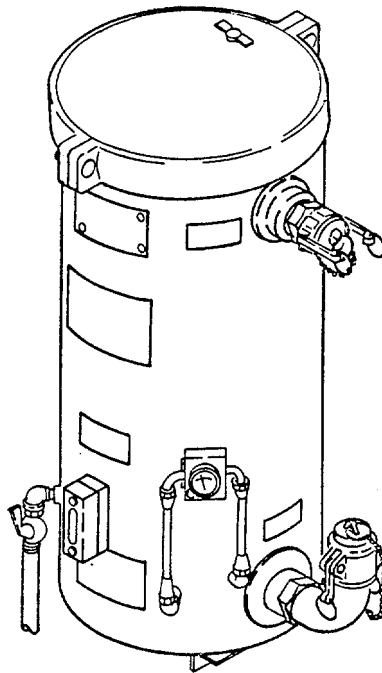

Approved for public release; distribution is unlimited.

*** This manual supersedes TM 5-4330-232-12&P, dated 19 April 1971, including all changes.**

**HEADQUARTERS, DEPARTMENT OF THE ARMY
3 SEPTEMBER 1991**

CHANGE

HEADQUARTERS
DEPARTMENT OF THE ARMY
WASHINGTON, D.C., 30 APRIL 1993

NO. 1

Operator's and Unit Maintenance Manual
(Including Repair Parts and Special Tools List)

FILTER/SEPARATOR, LIQUID FUEL, TYPE I FRAME MOUNTED 50 GPM CAPACITY
(MODEL 011F-Z-001) NSN 4330-00-250-4381
(MODEL 59FS50ALV) NSN 4330-00-250-4381
(MODEL GFS-4-V50AL) NSN 4330-00-250-4381
AND
MODEL 13217E7140 (97403) TYPE II NON-FRAME MOUNTED 50 GPM
FILTER/SEPARATOR NSN 4330-01-012-3313

DISTRIBUTION STATEMENT A: Approved for public release; distribution is unlimited.

TM 10-4330-232-12&P, 3 September 1991, is changed as follows:

1. Remove and insert pages as indicated below. New or changed text material is indicated by a vertical bar in the margin. An illustration change is indicated by a miniature pointing hand.

Remove pages	Insert pages
i and ii	i and ii
2-5 and 2-6	2-5 and 2-6
----	2-6.1/(2-6.2 blank)
4-7 and 4-8	4-7 and 4-8
4-33 and 4-34	4-33 through 4-36
B-1 through B-4	B-1 through B-4
F-1/(F-2 blank)	F-1 through F-6
----	Figure 1 (Sheet 1 of 2)
----	through F-5-1
----	Section III
----	I-1 through I-5/(I-6 blank)

2. Retain this sheet in front of manual for reference purposes.

By Order of the Secretary of the Army:

Official: *Milton H. Hamilton*

MILTON H. HAMILTON
Administrative Assistant to the
Secretary of the Army
04273

GORDON R. SULLIVAN
General, United States Army
Chief of Staff

DISTRIBUTION:

To be distributed in accordance with DA Form 12-25-E, block no. 5475, requirements for TM 10-4330-232-12&P.

WARNING

Take particular heed to specific WARNINGS and CAUTIONS throughout this manual.

Dry cleaning solvent, PD-680, used to clean parts is potentially dangerous to personnel and property. Avoid repeated or prolonged skin contact. Do not use near open flame or excessive heat. Flash point of solvent is 100 - 138°F (38 -60°C).

Do not smoke or use open flame in vicinity of filter/separator. Use protective equipment to prevent skin and eye contact with fuel.

Make sure fire extinguishers and fire fighting equipment are available in the immediate area. Be extremely careful when using fire extinguisher in an enclosed area. Provide adequate ventilation.

Do not drain fuel from the unit on the ground. Drain fuel into a container that can be closed, otherwise a fire hazard or environmental contamination could result.

Use protective equipment to prevent skin and eye contact with fuel.

Use rubber fuel resistant gloves when replacing filter elements due to toxic effects of some fuel additives.

Dispose of filter elements in accordance with local policy.

Do not operate the filter/separator unit until it has been connected to suitable ground. A static discharge could ignite the fuel or cause an explosion of the fuel vapor.

Use a lifting device with a lifting capacity of at least one ton. Do not allow unit to swing back and forth while hanging in the air. If you fail to heed this warning, serious injury or death may occur to personnel or, the equipment may be damaged.

For artificial respiration, refer to FM 21-11.

a/(b blank)

TECHNICAL MANUAL
NO. 10-4330-232-12&P

HEADQUARTERS,
DEPARTMENT OF THE ARMY
WASHINGTON D.C., 3 September 1991

Operator's and Unit Maintenance Manual
(Including Repair Parts and Special Tools List)

FILTER/SEPARATOR, LIQUID FUEL, TYPE I FRAME MOUNTED, 50 GPM CAPACITY
(MODEL 011F-Z-001) NSN 4330-00-250-4381
(MODEL 59FS50ALV) NSN 4330-00-250-4381
(MODEL GFS-4-V50AL) NSN 4330-00-250-4381
AND
MODEL 13217E7140 (97403) TYPE II NON-FRAME MOUNTED 50 GPM
FILTER/SEPARATOR NSN 4330-01-012-3313

Current as of 18 March 1993

REPORTING ERRORS AND RECOMMENDING IMPROVEMENTS

You can help improve this manual. If you find any mistakes or if you know of a way to improve the procedures, please let us know. Mail your letter, DA Form 2028 (Recommended Changes to Publications and Blank Forms), or DA Form 2028-2 located in the back of this manual direct to: Commander, US Army Aviation and Troop Command, ATIN: AMSAT-I-MP, 4300 Goodfellow Blvd., St. Louis, MO 63120-1798. A reply will be furnished directly to you.

DISTRIBUTION STATEMENT A: Approved for public release; distribution is unlimited.

TABLE OF CONTENTS

	Illus/ Page	Figure
CHAPTER 1 INTRODUCTION		
OVERVIEW	1-1	
Section I General	1-1	
Section II Equipment Description and Data	1-2	
Section III Technical Principles of Operation	1-6	
CHAPTER 2 OPERATING INSTRUCTIONS		
OVERVIEW	2-1	
Section I Operator's Controls and Indicators	2-1	
Section II Operator's Preventive Maintenance Checks and Services (PMCS)	2-3	
Section III Operation Under Usual Conditions	2-7	
Section IV Operation Under Unusual Conditions	2-12	
CHAPTER 3 OPERATOR'S MAINTENANCE INSTRUCTIONS		
OVERVIEW	3-1	

* This manual supersedes TM 5-4330-232-12&P, dated 19 April 1971, including all changes.

		Illus/ Page	Figure
Section I	Lubrication Instructions	3-1	
Section II	Operator Troubleshooting Procedures	3-1	
Section III	Operator's Maintenance Procedures.....	3-3	
CHAPTER 4 UNIT MAINTENANCE			
	OVERVIEW	4-1	
Section I	Repair Parts; Special Tools; and Support Equipment	4-1	
Section II	Service Upon Receipt	4-1	
Section III	Unit Preventive Maintenance Checks and Services (PMCS) ..	4-4	
Section IV	Unit Troubleshooting	4-5	
Section V	Unit Maintenance Procedures	4-7	
Section VI	Preparation for Shipment or Storage	4-34	
APPENDIX A	REFERENCES	A-1	
APPENDIX B	MAINTENANCE ALLOCATION CHART	B-1	
APPENDIX C	COMPONENTS OF END ITEM AND BASIC ISSUE ITEMS LISTS.....	C-1	
APPENDIX D	ADDITIONAL AUTHORIZATION LIST	D-1	
APPENDIX E	EXPENDABLE/DURABLE SUPPLIES AND MAERLALS LIST	E-1	
APPENDIX F	REPAIR PARTS AND SPECIAL TOOLS LIST	F-1	
Section I	Introduction	F-1	
Section II	Repair Parts List	F-1	
Group 01	Cover Tank and Frame Tank and Frame	F-1	
Group 02	Valves, Lines, and Fittings Valves, Lines, and Fittings	F-2-1	F-2
Group 03	Sight Gage, and Differential Gage Sight Gage, and Differential Gage.....	F-3-1	F-3
Group 04	Grounding Rod Assembly Grounding Rod Assembly.....	F-4-1	F-4
Group 05	Water Detector Kit Water Detector Kit	F-5-1	F-5
Section III	Special Tools (Not Applicable)		
Section IV	Cross-Reference Indexes	I-1	
	National Stock Number Index	I-1	
	Part Number Index	I-2	
	Figure and Item Number Index.....	I-4	
APPENDIX G	ILLUSTRATED LIST OF MANUFAC ID ITEMS.....	G-1	
INDEX	Index 1	

LIST OF ILLUSTRATIONS

Figure Number	Title	Page
1-1	Filter/Separator, Liquid Fuel, 50 GPM Capacity	1-0
1-2	Location and Description of Major Components	1-4
2-1	Operator's Controls and Indicators	2-2
2-2	Starting the Filter/Separator	2-8
2-3	Operating the Filter/Separator	2-8
2-4	Stopping the Filter/Separator	2-9
3-1	Valves, Lines, Fittings, Service	3-4
4-1	Installing Filter/Separator	4-3
4-2	Typical Operational Layout	4-4
4-3	Cover, Replace	4-9
4-4	Manual Vent Valve, Replace	4-11
4-5	Coupling Gasket, Replace.....	4-13
4-6	Tank, Replace.....	4-15
4-7	Frame, Replace	4-17
4-8	Canister, Replace.....	4-19
4-9	Elements, Replace	4-21
4-10	Tube Assembly, Replace	4-22
4-11	Coupling Half Quick Disconnect (Inlet), Replace	4-23
4-12	Coupling Half Quick Disconnect (Outlet), Replace	4-24
4-13	Drain Cock, Replace	4-25
4-14	Drain Hose, Replace	4-26
4-15	Sight Gage, Replace	4-27
4-16	Differential Pressure Gage, Replace	4-29
4-17	Grounding Rod Assembly, Repair	4-31
4-18	Grounding Rod Assembly, Replace.....	4-33

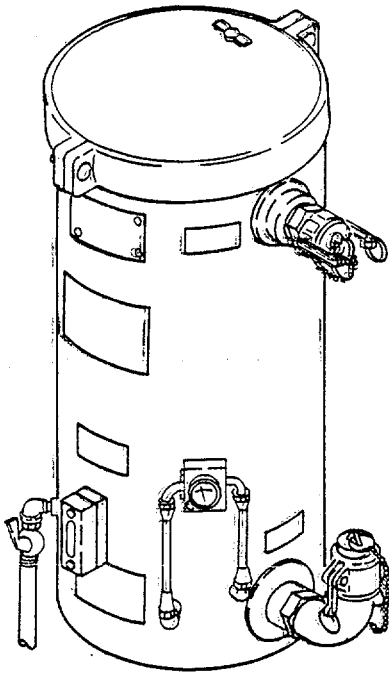

MODEL 13217E7140

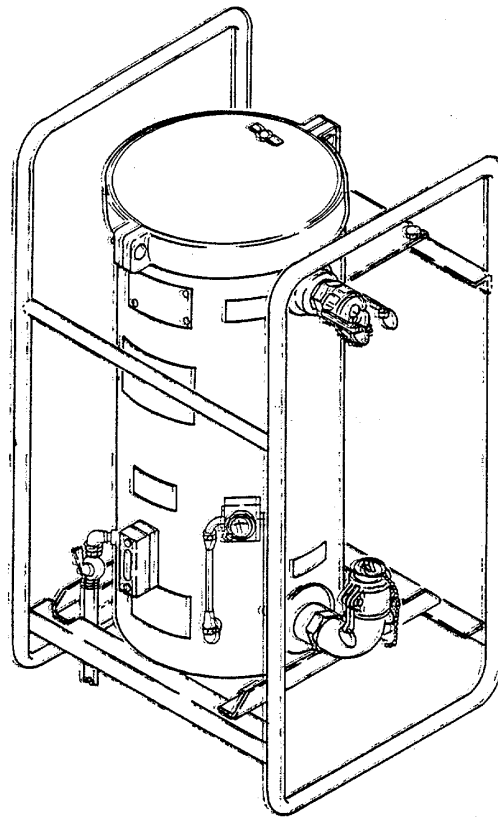

MODELS
.011F-Z-001
59FS50ALV
GFS-4-V50AL

Figure 1-1. Fitter/Separator, Liquid Fuel, 50 GPM Capacity.

CHAPTER 1

INTRODUCTION

	Page
OVERVIEW	1-1
Section I. General.....	1-1
Section II. Equipment Description and Data	1-2
Section III. Technical Principles of Operation	1-6

OVERVIEW

This chapter includes general information regarding the filter/separator as well as specific information pertinent to equipment description and data and technical principles of operation.

SECTION I. GENERAL

Paragraph		Page
1-1	Scope	1-1
1-2	Maintenance Forms, Records and Reports.....	1-1
1-3	Reporting Equipment Improvement Recommendations.....	1-2
1-4	Destruction of Army Materiel to Prevent Enemy Use	1-2
1-5	Preparation for Storage or Shipment	1-2
1-6	Hand Receipt Manual	1-2

1-1. **Scope.** The scope of this manual is described in the following subparagraphs.

a. Type of Manual. This manual provides operator and unit maintenance instructions for Filter/Separator, Liquid Fuel, Frame Mounted, 50 GPM Capacity NSN 4330-00-250-4381 and non-frame mounted, 50 GPM Capacity, Filter/Separator NSN 4330-01-012-3313 (figure 1-1). This manual also provides a Repair Parts and Special Tools List located at Appendix F.

b. Equipment Name. 50 GPM Capacity, Frame Mounted, Liquid Fuel Filter/Separator, hereinafter referred to as the filter/separator.

c. Purpose of Equipment. The filter/separator is a static device which is installed in a fuel system. The filter/separator is capable of removing entrapped water and solid contaminants from fuel.

1-2. **Maintenance Forms, Records and Reports.**

a. Reports of Maintenance and Unsatisfactory Equipment Department of the Army forms and procedures used for equipment maintenance will be those prescribed by DA Pam 738-750, in the Army Maintenance Management System (TAMMS) (Maintenance Management Update).

b. Reporting of Item and Packaging Discrepancies. Fill out and forward SF 364 (Report of Discrepancy (ROD)) as prescribed in AR 735-11-2.

1-3. **Reporting of Equipment Improvement Recommendations (EIR).** If your filter/separator needs improvement, let us know. Send us an EIR. You, the user, are the only one who can tell us what you don't like about your equipment. Let us know why you don't like the design or performance. Put it on an SF 368 (Product Quality Deficiency Report). Mail it to us at: Commander, U.S. Army Troop Support Command, ATTN: AMSTR-QS, 4300 Goodfellow Boulevard, St. Louis, Missouri 63120-1798. We will send you a reply.

1-4. **Destruction of Army Materiel to Prevent Enemy Use.** Refer to TM 750-244-3 for procedures to destroy equipment to prevent enemy use.

1-5. **Preparation for Storage or Shipment.** Refer to Chapter 4, section VI, for procedures to place the equipment into storage,

1-6. **Hand Receipt Manual.** Not applicable.

SECTION II. EQUIPMENT DESCRIPTION AND DATA

Paragraph		Page
1-7	Equipment Characteristics, Capabilities and Features	1-2
1-8	Location and Description of Major Components.....	1-3
1-9	Equipment Data	1-5
1-10	Differences Between Models.....	1-5
1-11	Safety, Care and Handling	1-5

1-7. Equipment Characteristics, Capabilities and Features.

a. Characteristics. The filter/separator is an upright frame mounted tank equipped with a removable cover, four filter elements and canisters, a water level sight gage, manual water drain cock, a manual vent valve, a differential pressure gage, and quick disconnect type inlet and outlet couplings. Model 13217E7140 is non-frame mounted.

b. Capabilities and Features.

- (1) Highly portable.
- (2) All weather operational.
- (3) Manual water drain valve.
- (4) 50 GPM (189 LPM) rating.

1-8. Location and Description of Major Components. (Figure 1-2)

FILTER/SEPARATOR TANK (1). Consists of an aluminum shell contained within an aluminum frame (except Model 13217E7140).

FILTERING SECTION (2). The center portion of the filter/separator shell contains four filter separating devices.

WATER DRAIN VALVE (3). Used to drain water out of filter/separator tank.

SIGHT GAGE (4). The sight gage gives a visual indication of where water and fuel interface.

DIFFERENTIAL PRESSURE GAGE (5). Reads the pressure required to force the fuel through the filter elements.

FRAME (Models 011 F-Z-001, 59FS50ALV, and GFS-4-V50AL) (6). Provides protection for the tank, and transportability of the filter/separator.

ADAPTER (7). Used to attach the fuel contamination test kit.

MANUAL VENT VALVE (8). Manually operated valve used to depressurize the filter/separator.

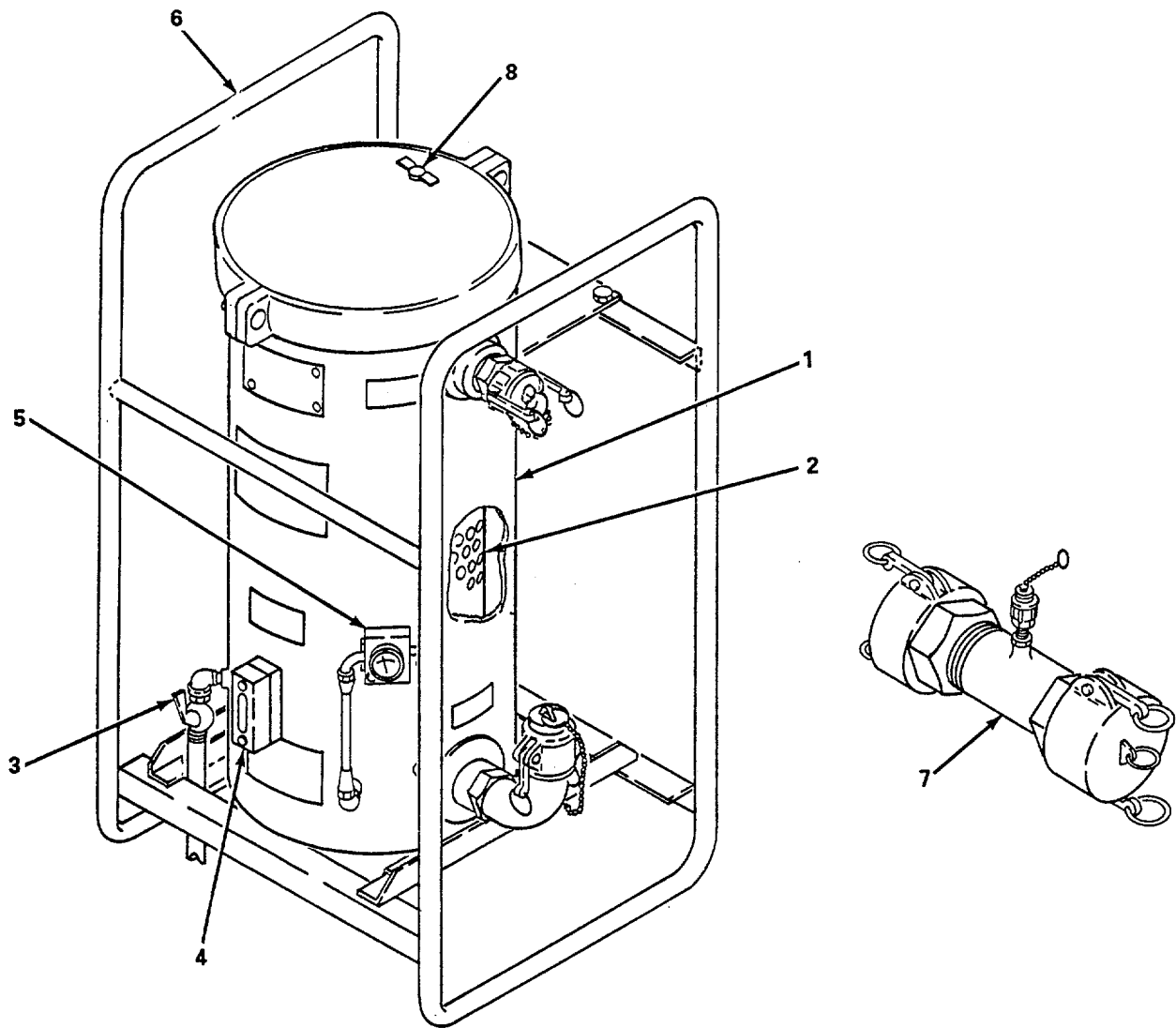

Figure 1-2. Location and Description of Major Components.

1-9. **Equipment Data.**

a. Filter/Separator.

Models 011 F-Z-001, 59FS50ALV, GFS-4-V50AL, 13217E7140
 Rating 50 GPM (189 LPM)
 Working Pressure..... 75 PSI (517 kPa) maximum

b. Differential Pressure Gage.

Range 0-40 PSI
 Fluid Service Light Petroleum Fuels
 Temperature Rating -25° to 125°F (-31.7° to 51.7°C)

c. Dimension and Weight (Models 01 IF-Z-001, 59FS50AL V. GFS-4-V50AL).

Height 36.00 in. (91.44 cm)
 Width 17.31 in. (43.96 cm)
 Length..... 20.50 in. (52.07 cm)
 Weight (dry) 85 lbs (38.59 kg)
 Shipping Cube (crated) 7.14 cu ft (0.19 cu m)

d. Dimension and Weight (Model 13217E7140).

Height 32.50 in. (82.55 cm)
 Width 18.75 in. (47.62 cm)
 Length 12.75 in. (32.38 cm)
 Weight (dry) 73 lbs (33.14 kg)

e. Canisters.

Part number 13217E6316
 Manufacturer..... Army Engineer Research and Development Laboratories

f. Elements.

Part number MIL-F-52308
 NSN..... 4330-00-983-0998

1-10. **Differences Between Models.** The only difference between models is that Model 13217E7140 is not frame mounted.

1-11. **Safety, Care, and Handling.** Observe all WARNINGS, CAUTIONS, and NOTES in this manual. This equipment can be extremely dangerous if these instructions are not followed.

SECTION III. TECHNICAL PRINCIPLES OF OPERATION**1-12. Technical Principles of Operation.**

a. General. The filter/separator is a static device which is installed in a fuel system to remove water and solid contaminants from the fuel. The filter/separator is normally installed between the fuel system pump and the fuel dispensing equipment. Thus, fuel is pushed through the filter/separator by pump action.

b. Simplified Principles of Operation. Fuel enters through the inlet connection and passes through the filter center tube and passes towards the outside of the element. Upon reaching the exterior of the element the fuel passes through the layers of plated paper, cotton knit and screen. The water droplets, being heavier than fuel, fall to the bottom of the tank. As water collects in the tank, the water level rises. Clean fuel floats on top of this water. The point at which the fuel and water meet is known as the interface. The liquid level gage gives a visual indication of this interface. Manual controls permit the discharge of the separated water and prevents the flow of fuel out of the filter/separator.

CHAPTER 2
OPERATING INSTRUCTIONS

		Page
	OVERVIEW	2-1
Section I.	Operator's Controls and Indicators	2-1
Section II.	Operator's Preventive Maintenance Checks and Services (PMCS)	2-3
Section III.	Operation Under Usual Conditions	2-6
Section IV.	Operation Under Unusual Conditions	2-12

OVERVIEW

This chapter covers operator controls and indicators, operator PMCS, and the operation of the filter/separator under usual and unusual conditions.

SECTION I. OPERATOR'S CONTROLS AND INDICATORS

Paragraph		Page
2-1	General.....	2-1
2-2	Operators Controls and Indicators	2-1

2-1. **General.** The filter-separator is equipped with a manually operated drain valve, a manual vent valve, differential pressure gage, and a liquid level sight gage.

2-2. **Operator's Controls and Indicators.** Figure 2-1 illustrates the operator's controls and indicators for the filter/separator.

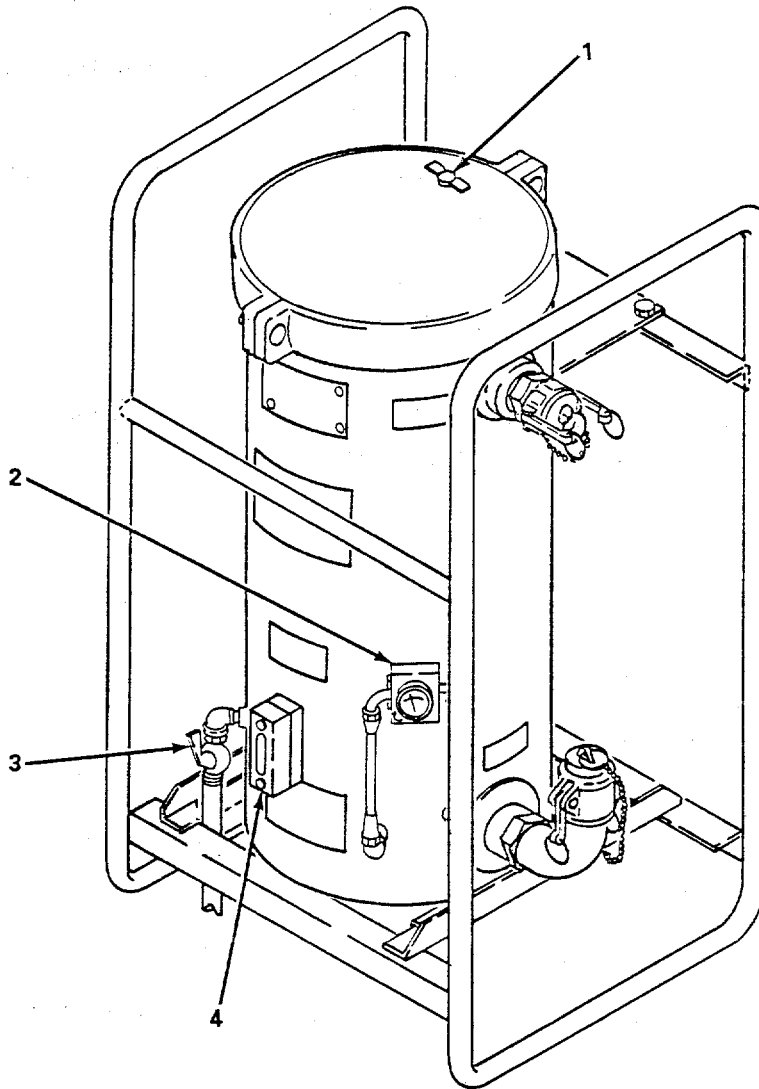

Figure 2-1. Operator's Controls and Indicators.

Key	Control or Indicator	Function
1	Manual Vent Valve	Manually operated to depressurize the filter/separator.
2	Differential Pressure Gage	Indicates the pressure required to force the fuel through the filter elements.
3	Water Drain Cock	Provides a way to manually drain the filter/separator tank.
4	Sight Gage	Gives a visual indication of where water and fuel interface.

SECTION II. OPERATOR'S PREVENTIVE MAINTENANCE CHECKS AND SERVICES (PMCS)

Paragraph		Page
2-3	General.....	2-3
2-4	Purpose of PMCS Table	2-3
2-5	Explanation of Columns	2-3
2-6	Equipment is Not Ready/Available If Column	2-4
2-7	Reporting Deficiencies	2-4
2-8	Special Instructions	2-4

2-3. **General.** Operator PMCS are performed to ensure that the filter/separator is ready for operation at all times. Perform the checks and services at the specified intervals.

- a. Before you operate, perform your before (B) PMCS. Observe all CAUTIONS and WARNINGS.
- b. While you operate, perform your during (D) PMCS. Observe all CAUTIONS and WARNINGS.
- c. After you operate, be sure to perform your after (A) PMCS.
- d. If your equipment fails to operate, refer to paragraph 3-3, operator's troubleshooting procedures.

2-4. **Purpose of PMCS Table.** The purpose of the PMCS table is to provide a systematic method of inspecting and servicing the equipment. In this way, small defects can be detected early before they become a major problem causing the equipment to fail to complete its mission. The PMCS table is arranged with the individual PMCS procedures listed in sequence under assigned intervals. The most logical time (before, during, or after operation) to perform each procedure determines the interval to which it is assigned. Make a habit of doing the checks in the same order each time and anything wrong will be seen quickly. See paragraphs 2-5 and 2-6 for an explanation of the columns in table 2-1.

2-5. **Explanation of Columns.** The following is a list of the PMCS table column headings with a description of the information found in each column.

a. Item No. This column shows the sequence in which the checks and services are to be performed, and is used to identify the equipment area on the Equipment Inspection and Maintenance Worksheet, DA Form 2404.

b. Interval. This column shows a dot when each check is to be done.

c. Item to be Inspected/Procedures. This column identifies the general area or specific part where the check or service is to be done, and explains how to do them.

d. Equipment is Not Ready/Available If. See paragraph 2-6.

2-6. **Equipment is Not Ready/Available If.** This column lists conditions that make the equipment unavailable for use because it is unable to perform its mission, or because it would represent a safety hazard. Do not accept or operate equipment with a condition in the "Equipment is Not Ready/Available If" column.

NOTE

The terms ready/available and mission capable refer to the same status: Equipment is on hand and is able to perform its combat mission. Refer to DA Pam 738-750.

2-7. **Reporting Deficiencies.** If any problem with the equipment is discovered during PMCS or while it is being operated that cannot be corrected at the operator/crew maintenance level, it must be reported. Refer to DA Pam 738-750 and report the deficiency using the proper forms.

2-8. **Special Instructions.** Preventive maintenance is not limited to performing the checks and services listed in the PMCS table.

WARNING

Dry-cleaning solvent PD-680 used to clean parts is potentially dangerous to personnel and property. Avoid repeated and prolonged skin contact. Do not use near open flame or excessive heat. Flash point of solvent is 100 - 138°F (38 - 60°C).

a. Keep it clean. Dirt, grease, oil, and debris get in the way and may cover up a serious problem. Clean as you work and as needed. Use dry-cleaning solvent on all metal surfaces. Use soap and water to clean rubber or plastic material.

b. Bolts, Nuts, and Screws. Check them all for obvious looseness, missing, bent, or broken condition. You can't try them all with a tool, but look for chipped paint, bare metal, or rust around boltheads. If you find one you think is loose, tighten it, or report it to unit maintenance if you can't tighten it.

c. Fluid Lines. Look for wear, damage, and leaks. Make sure clamps and fittings are tight. Wet spots and stains around a fitting or connector can mean a leak. If a leak comes from a loose connector, tighten it. If something is broken or worn out, report it to unit maintenance.

d. Leakage Definitions. It is necessary for you to know how fluid leakage affects the status of your equipment. The following are definitions of the types/classes of leakage you need to know to be able to determine the status of your equipment. Learn and be familiar with them. When in doubt, NOTIFY YOUR SUPERVISOR!

Leakage Definitions:

Class I	Seepage of fluid (as indicated by wetness or discoloration) not great enough to form drops.
Class II	Leakage of fluid great enough to form drops but not enough to cause drops to drip from item being checked/inspected.
Class III	Leakage of fluid great enough to form drops that fall from the item being checked/inspected.

CAUTION

Equipment operation is allowable with minor leakage (Class I or II) of any fluid except fuel. Of course, consideration must be given to the fluid capacity in the item being checked/inspected. When in doubt, notify your supervisor.

When operating with Class I or II leaks, continue to check fluid level more often than required in the PMCS.

Class III leaks should be reported to your supervisor or unit maintenance.

- e. Painting. Touch-up filter/separator as needed. Refer to TM 43-0139 for specific painting procedures.

Table 2-1. Operator Preventive Maintenance Checks and Services (PMCS).

NOTE

Within designated intervals, these checks are to be performed in the order listed.

If the equipment must be kept in continuous operation, check and service only those items that can be checked and serviced without disturbing the operation. Make the complete checks and services when the equipment can be shut down.

Table 2-1. Preventive Maintenance Checks and Services for
50 GPM Filter/Separator

Item	Interval	Item to Check/Service	Procedure	Not Fully Mission Capable If:
1	BEFORE	Diff. Pressure Gage	Inspect for secure mounting, loose connections or damage.	Gage is damaged. body.. Valve is inoperable.
2	BEFORE	Tube Assemblies	Inspect for kinks, breaks and loose fittings.	
3	BEFORE	Sight Gage	Inspect for cracked gage body. See that mounting screws are tight	
4	BEFORE	Pressure Vent Valve	Press valve to check operation.	
5	BEFORE	Drain Valve	See that handle is CLOSED.	
<u>WARNING</u>				
Failure to properly ground filter/separator prior to operation could allow a static discharge (spark) which could ignite fuel or cause an explosion of fuel vapor.				
6	BEFORE	Ground Rod	Inspect that ground cable is secure to rod.	Cable not secure.
7	BEFORE	Plates	Inspect that all instruction and warning plates are legible.	
8	BEFORE	Tank and Frame	Inspect for damage, loose or missing hardware.	Hardware is missing.
9	BEFORE	Adapter and Probe	Inspect that adapter and probe are secure.	
10	DURING	Diff. Pressure Gage	Inspect gage indication. If yellow, see table 3-1.	Indication is in red.
11	DURING	Sight Gage	Check water level. Drain when ball reaches mark.	

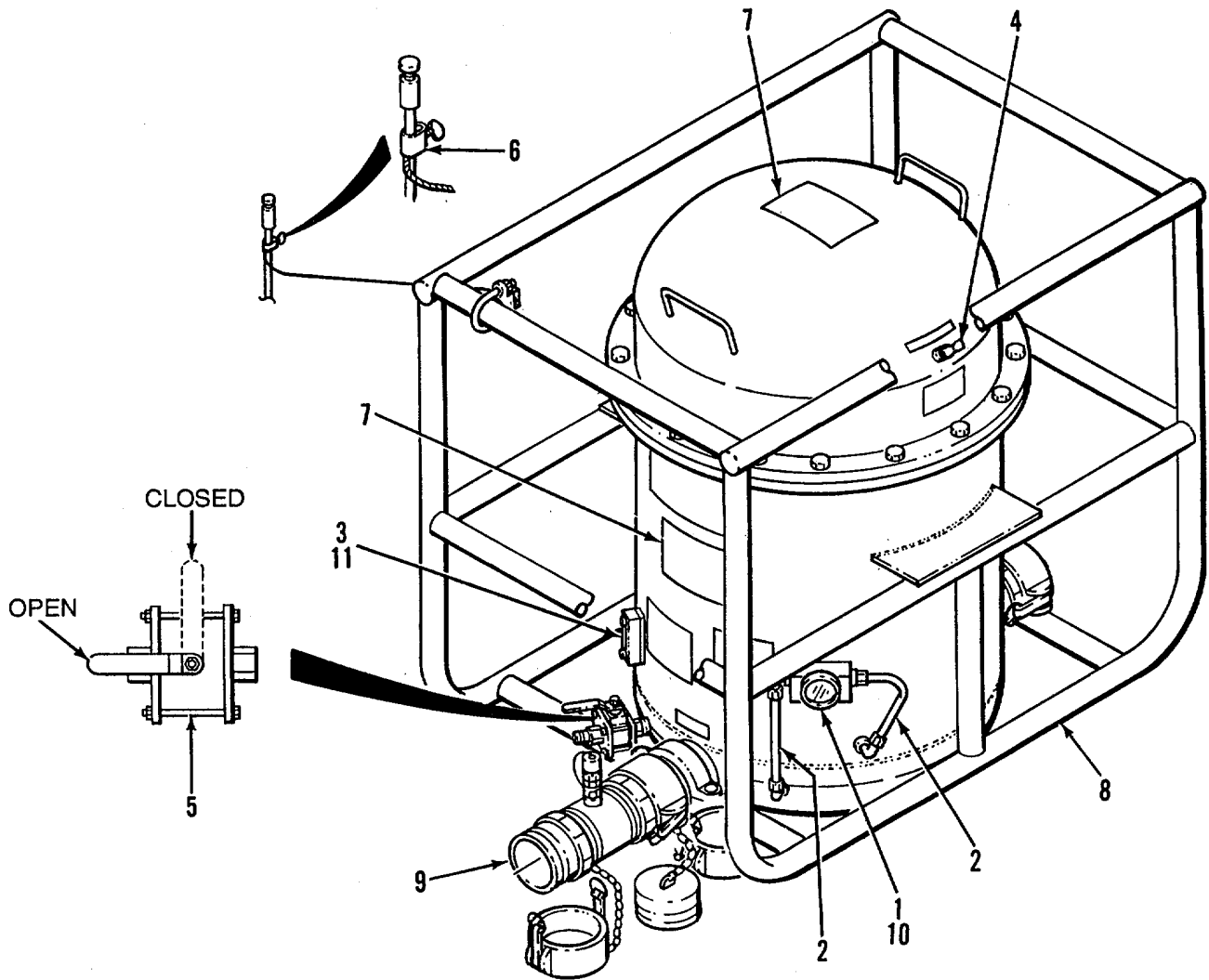

2-6.1(2-6.2 blank)

SECTION III. OPERATION UNDER USUAL CONDITIONS

Paragraph		Page
2-9	Starting Procedure	2-7
2-10	Operating.....	2-8
2-11	Stag Procedure	2-10

2-9. Starling Procedure. (Figure 2-2)

WARNINGS

- Do not operate the filter/separator unit until it has been connected to a suitable ground. A static discharge could ignite the fuel or cause an explosion of the fuel vapor.
- Do not smoke or use open flame in vicinity of filter/separator. Use protective equipment to prevent skin and eye contact with fuel.
- Make sure fire extinguishers and fire fighting equipment are available in the immediate area. Be extremely careful when using a fire extinguisher in an enclosed area. Provide adequate ventilation.

- a. Make sure that the water drain cock (1) is closed.
- b. Remove inlet plug (2) and outlet cap (3).
- c. Install adapter (4) onto outlet fitting (6) with arrow in direction of flow.
- d. Ensure the inlet (5) and outlet (6) connections are tight.
- e. Open the manual vent valve (7) by moving to the down position to allow entrapped air to escape.
- f. Start the system pumping unit. Refer to applicable system pumping technical manual.
- g. Open any inlet blocking valves slightly to allow the filter/separator (8) to fill slowly with as little pressure as possible.

NOTE

When the unit is completely filled, fuel will come through the manual vent valve.

- h. Close manual vent valve (7) when fuel comes through valve. Make a visual inspection of all connections, joints, and piping components for leaks.
- i. Open inlet blocking valves fully.

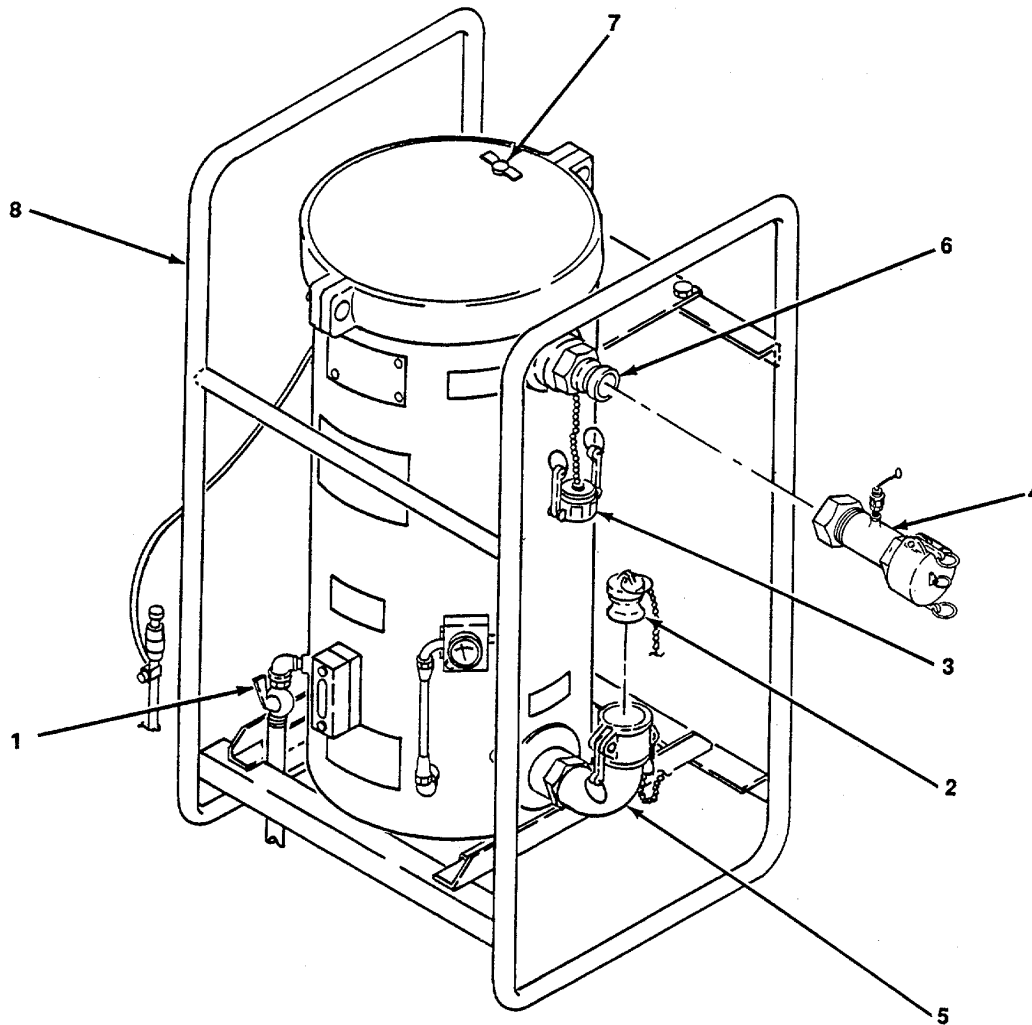

Figure 2-2. Starting the Filter/Separator.

2-10. **Operating.** (Figure 2-3)

- a. Observe the differential pressure gage (1). If reading is 0-20 psi (Green), continue operation. If reading is 20-35 psi (Yellow) continue operation and notify unit maintenance upon completion of refueling operation. If reading rises above 35 psi (Red) shutdown operation and notify unit maintenance.
- b. During operation, periodically check the water level sight gage (2). If the water level reaches the center mark, open the water drain cock (3) and drain water into suitable container until water level ball is at lowest position, then close valve.

NOTE

Ensure water is drained daily.

- c. Perform a fuel sampling test using Test Kit (NSN 6640-00-244-9478).

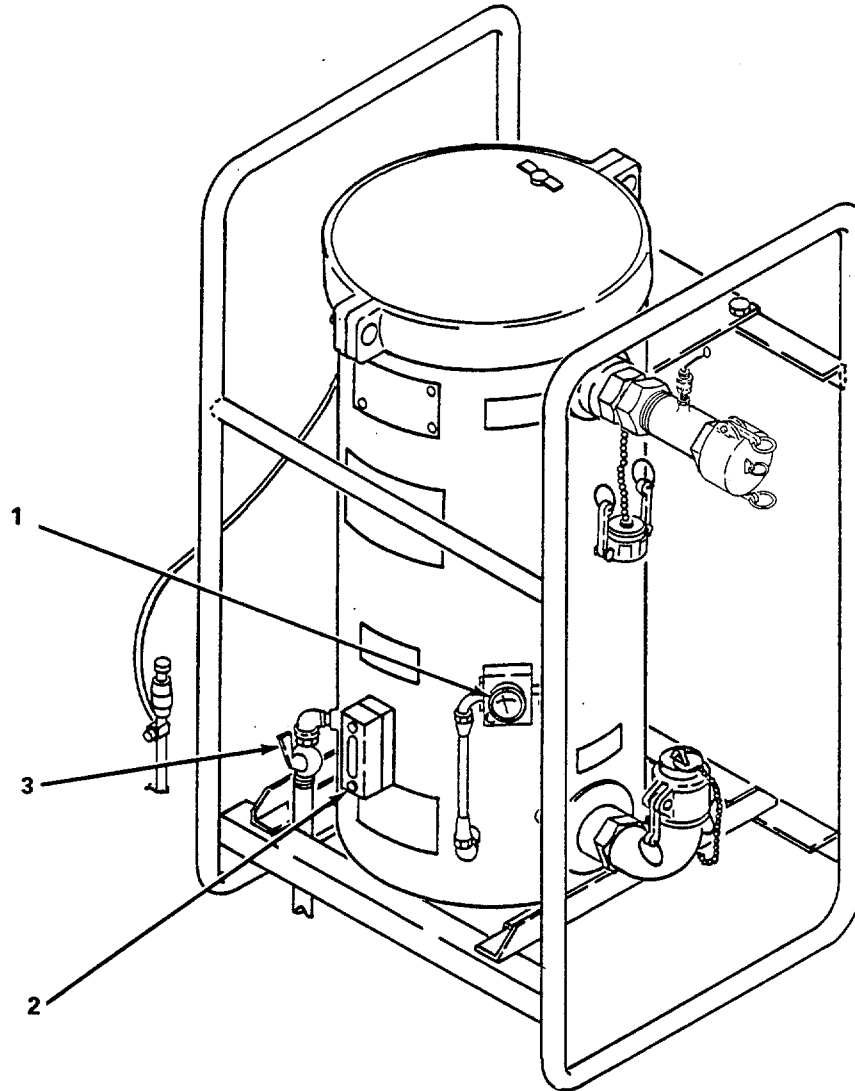

Figure 2-3. Operating the Filter/Separator.

2-11. Stopping Procedure. (Figure 2-4)

- a. Stop the system pumping unit. Refer to applicable system pumping technical manual.
- b. Close the inlet blocking, valve
- c. Close the outlet blocking valve.
- d. Open the manual vent valve (1) by pushing valve down slightly. Close after venting.

NOTE

If the filter/separator is not to be in frequent use, drain the tank Use following instructions.

WARNINGS

- Do not drain fuel from the unit on the ground. Drain fuel into a container that can be closed, otherwise fire hazard or environmental contamination could result.
 - Use protective equipment to prevent skin and eye contact with fuel.
- e. Open manual vent valve (1) fully.
 - f. Open water drain cock (2) and drain tank (3).
 - g. Close water drain cock (2) and manual vent valve (1).
 - h. Remove adapter (4).
 - i. Clean inlet plug (5) and outlet cap (6) and install.

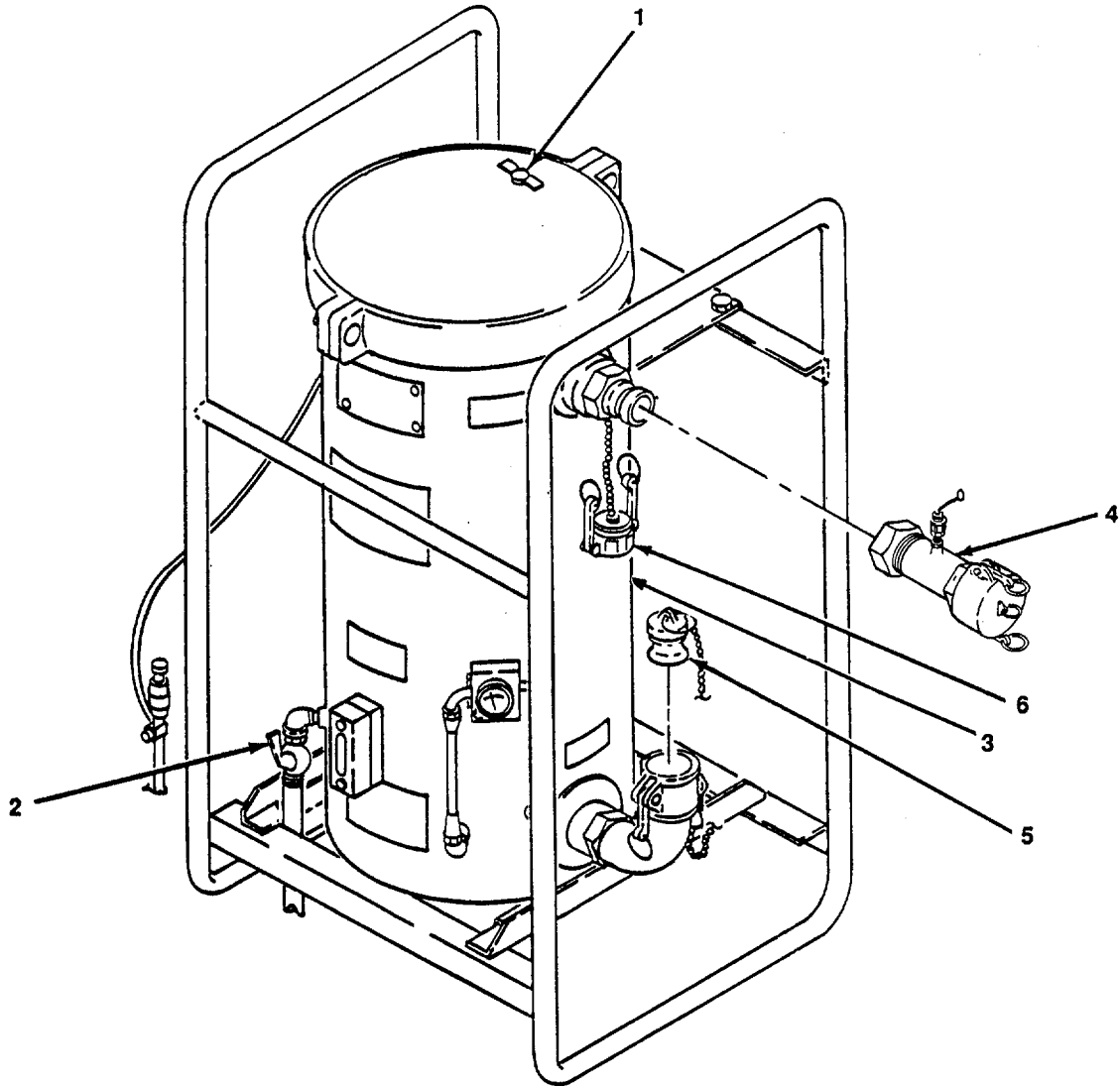

Figure 2-4. Stopping the Filter/Separator.

SECTION IV. OPERATION UNDER UNUSUAL CONDITIONS

Paragraph		Page
2-12	Operation in Extreme Cold.....	2-12
2-13	Operation in Extreme Heat.....	2-12
2-14	Operation in Dusty or Sandy Areas	2-12
2-15	Operation in Rainy or Humid Conditions.....	2-12
2-16	Operation in Salt Water Areas.....	2-13
2-17	Operation at High Altitudes	2-13

2-12. **Operation in Extreme Cold.** The procedures for starting and stopping the filter/separator are the same as under usual conditions except for the following special precautions.

- a. Water must be drained more frequently than usual and at each shut down to avoid freezing.
- b. If possible provide a heated shelter.
- c. Check differential pressure gage regularly to be sure that pressure limits are not being exceeded.

2-13. **Operation in Extreme Heat.** The procedures for starting and stopping the filter/separator are the same as under usual conditions except for the following special precautions.

- a. Erect a screen or shelter to provide shade.
- b. Check differential pressure gage regularly to be sure that the pressure limits are not being exceeded.
- c. Vent filter/separator when not in operation, and collect the discharge of the liquid.

2-14. **Operation in Dusty or Sandy Areas.** The procedures for starting and stopping the filter/separator are the same as under usual conditions except for the following special precautions:

- a. Under dusty or sandy conditions, filter elements must be replaced more frequently.
- b. Select a work site protected by natural barriers or erect screens of dustproof material.
- c. Keep the unit free of dust and dirt, especially when the unit is open for servicing or repair.
- d. Check the differential pressure gage regularly to make sure that pressure limits are not being exceeded.
- e. Ensure inlet plug and outlet cap are installed when hoses are removed.

2-15. **Operation in Rainy or Humid Conditions.** The procedures for starting and stopping the filter/separator are the same as under usual conditions except for the following special precautions.

- a. Water must be drained through the water drain valve more often than under normal conditions.
- b. Erect a shelter to prevent the entrance of rain into the interior of the unit when it is opened for servicing.

c. Check differential pressure gage regularly to be sure that pressure limits are not being exceeded.

2-16. Operation in Salt Water Areas. The procedures for starting and stopping the filter/separator are the same as under usual conditions except for the following special precautions.

a. Water must be drained through the water drain valve more often than under normal conditions.

b. Wipe down the filter/separator with a lightly oiled rag to prevent corrosion.

2-17. Operation at High Altitudes. The procedures for starting and stopping the filter/separator are the same as under usual conditions.

2-13/(2-14 blank)

CHAPTER 3

OPERATOR'S MAINTENANCE INSTRUCTIONS

	Page
OVERVIEW	3-1
Section I. Lubrication Instructions	3-1
Section II. Operator's Troubleshooting	3-1
Section III. Operator's Maintenance Procedures.....	3-3

OVERVIEW

This chapter contains operator level troubleshooting and maintenance.

SECTION I. LUBRICATION INSTRUCTIONS

Paragraph		Page
3-1	General.....	3-1

3-1. General. The filter/separator requires no lubrication.

Section II. OPERATOR'S TROUBLESHOOTING

Paragraph		Page
3-2	General.....	3-1
3-3	Operator Troubleshooting Procedures.....	3-1

3-2. General. This section contains troubleshooting procedure to determine the probable cause of observed equipment malfunctions. Inspections are provided to isolate the faulty component and corrective actions are provided to eliminate the malfunction.

3-3. Operator Troubleshooting Procedures. Refer to symptom index to locate the troubleshooting procedure of the observed malfunction.

a. Table 3-1 lists the common malfunctions which you may find during operations or maintenance of the filter/separator or its components. You should perform the tests/inspections and corrective actions are provided to eliminate the malfunction.

b. This manual cannot list all malfunctions that may occur, nor all test or inspections and corrective actions. If a malfunction is not connected by listed corrective actions, notify your supervisor.

SYMPTOM INDEX

Symptom	Page
No fuel delivery	3-2
General fuel leakage	3-2
Discharged fuel contains water	3-3
Sudden increase/decrease in pressure differential gage reading	3-3

Table 3-1. Operator Troubleshooting Procedures.

MALFUNCTION	TEST OR INSPECTION	CORRECTIVE ACTION
1. NO FUEL DELIVERY.		
	Step 1. Check to see if system pumping unit is operating properly.	Refer to applicable pumping unit technical manual.
	Step 2. Check hoses to ensure they are connected.	If not connected, notify unit maintenance.
	Step 3. Check to see if inlet and outlet blocking valves are open.	If closed, open valves.
	Step 4. Check differential pressure gage for reading.	Note reading and notify unit maintenance.
2. GENERAL FUEL LEAKAGE.		
	Step 1. Check lines and fittings.	If loose, notify unit maintenance.
	Step 2. Check for cracks or breaks in tank and components.	If cracks or breaks are found, notify unit maintenance.

Table 3-1. Operator Troubleshooting Procedures (cont).

MALFUNCTION	TEST OR INSPECTION	CORRECTIVE ACTION
3. DISCHARGED FUEL IS CONTAMINATED.		
	Step 1. Check water level in tank	Drain if water level is high.
	Step 2. Check differential pressure gage to see if needle is in the RED area.	If needle is in red area, notify unit maintenance.
4. SUDDEN INCREASE/DECREASE IN PRESSURE DIFFERENTIAL GAGE READING.		
	Step 1. Check to see if system pump is operating correctly.	Refer to applicable pumping unit technical manual.
	Step 2. Perform fuel sampling test.	If problem still exists, notify unit maintenance.

SECTION III. OPERATOR'S MAINTENANCE PROCEDURES

Paragraph		Page
3-4	General.....	3-3
3-5	Valves, Lines, and Fittings	3-4

3-4. General. This section contains operator level maintenance procedures.

3-5. Valves Lines, and Fittings.

This task covers: Service

INITIAL SETUP**Materials/Parts:**Wiping Rags (Item 4, Appendix E)

Service. (figure 3-1)**NOTE**

The procedures are the same for both the inlet and outlet fittings.

- (1) Remove dust cap (1) from outlet fitting (2).
- (2) Inspect gasket (3) and replace if torn or otherwise damaged.
- (3) Wipe dust cap (1) with rag.
- (4) Install dust cap (1).

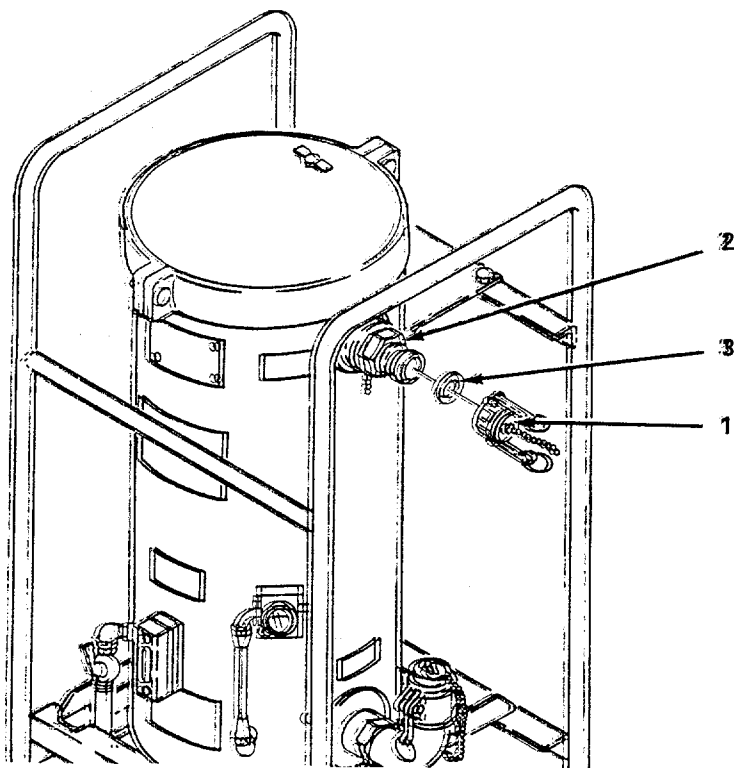

Figure 3-1. Valves, Lines, and Fittings, Service.

CHAPTER 4

UNIT MAINTENANCE

	Page
OVERVIEW	4-1
Section I. Repair Parts; Special Tools; and Support Equipment	4-1
Section II. Service Upon Receipt	4-1
Section III. Unit Preventive Maintenance Checks and Services (PMCS)	4-4
Section IV. Unit Troubleshooting	4-5
Section V. Unit Maintenance Instructions	4-7
Section VI. Preparation for Shipment or Storage	4-34

OVERVIEW

This chapter contains those maintenance instructions that unit level maintenance is authorized to perform.

SECTION I. REPAIR PARTS, SPECIAL TOOLS, AND SUPPORT EQUIPMENT

Paragraph		Page
4-1	Common Tools and Test Equipment	4-1
4-2	Special Tools, and Support Equipment.....	4-1
4-3	Repair Parts.....	4-1

4-1. Common Tools and Test Equipment. For authorized common tools and equipment, refer to the Modified Table of Organization and Equipment (MTOE) applicable for your unit.

4-2. Special Tools and Support Equipment. For a listing of special tools and support equipment authorized for use on this equipment, refer to the Repair Parts and Special Tools List, Appendix F, and the maintenance allocation chart (MAC), appendix B of this manual.

4-3. Repair Parts. Repair parts are listed and illustrated in the Repair Parts and Special Tools List, Appendix F.

SECTION II. SERVICE UPON RECEIPT

Paragraph		Page
4-4	Unloading	4-2
4-5	Unpacking.....	4-2
4-6	Inspection	4-2
4-7	Installation	4-2

WARNING

Use a lifting device with a lifting capacity of at least one ton. Do not allow unit to swing back and forth while hanging in the air. If you fail to heed this warning, serious injury or death may occur to personnel or the equipment may be damaged.

4-4. Unloading.

- a. When the filter/separator is received in a crated condition, unload it as near as possible to its operating or storage site.
- b. Use a lifting sling attached to a hoist or crane and lift the crate from the carrier.

4-5. Unpacking.

- a. Dismantle the crate, removing top, sides, and ends from the skid base.
- b. Remove all tie downs and blocking that secure the filter/separator to the skid base.

WARNING

Two personnel required to lift filter/separator to avoid injury.

- c. Lift the unit from the skid base and place it in position.

4-6. Inspection. Make a general visual inspection of the unit to ensure that it is complete. Make sure that no physical damage has been done during shipment.

4-7. Installation. (Figure4-1)

- a. This unit will usually be installed in a pipeline, therefore it's installation will be of a more or less permanent nature.
- b. The filter/separator must be placed at a level site in an upright position.
- c. Drive ground rod (1) into earth at least 8 feet deep, and fasten ground cable to the ground rod and to filter/separator.
- d. Connect water detector kit adapter (2) to outlet connection (3) of filter separator (4).
- e. Connect outlet hose from pumping unit to inlet connection (5) on the filter/separator. Connect outlet hose to outlet connection (3) or to water detector kit adapter (2).
- f. Ensure probe (6) has bevel facing fuel flow.
- g. Refer to figure 4-2 for typical filter/separator operational layout.

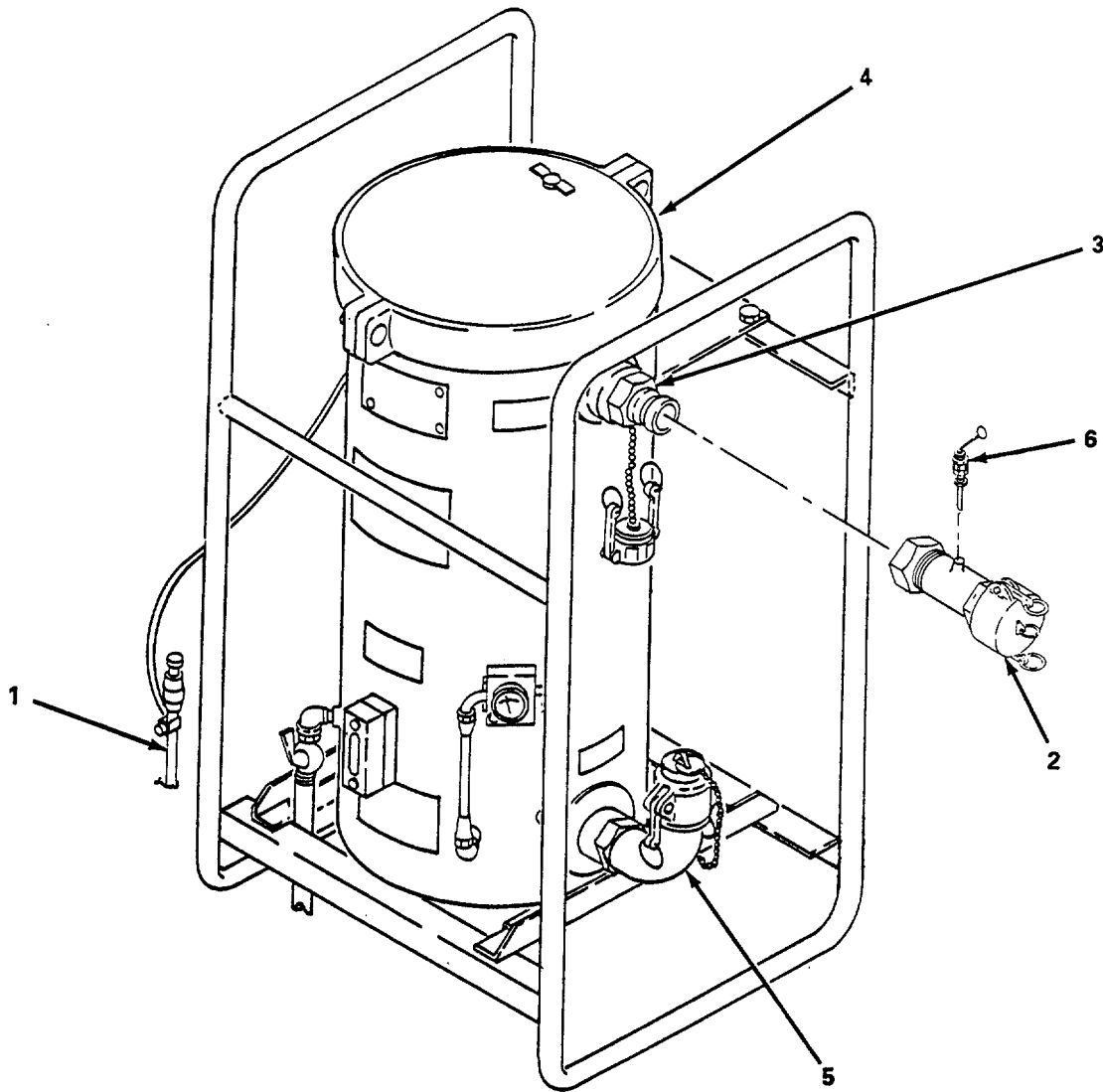

Figure 4-1. Installing Filter/Separator.

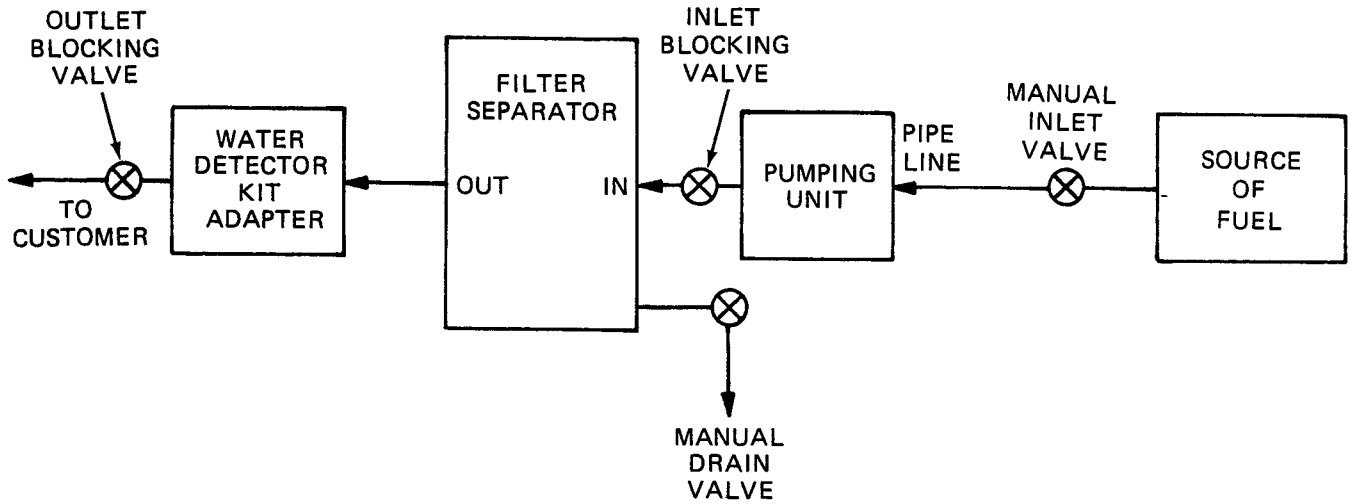

Figure 4-2. Typical Operational Layout.

SECTION III. UNIT PREVENTIVE MAINTENANCE CHECKS AND SERVICES (PMCS)

Paragraph		Page
4-8	General.....	4-4
4-9	PMCS Procedures.....	4-4

4-8. General. Unit level maintenance PMCS are done to ensure that the filter/separator is in operating condition. A comprehensive PMCS program reduces equipment downtime and increases the operational readiness of the filter/separator.

4-9. PMCS Procedures. Unit level PMCS is contained in table 4-1. The numbers in the Item No. Column show the order in which the check or service should be done. These numbers should be used when recording deficiencies and shortcomings on DA Form 2404. Equipment inspection and Maintenance Worksheet. The in the interval column indicates when a check or service should be done, as follows:

Table 4-1. Unit Preventive Maintenance Checks and Services (PMCS).

Q - Quarterly

Item No.	Interval	Item to be Inspected	Procedures
	Q		
1	•	Water Level Sight Gage	Inspect body of sight gage for breaks and cracks, replace defective sight gage (para. 4-20).
2	•	Manual Vent Valve	Check that manual vent valve operates freely and no damage is visible. Replace a defective manual vent valve (para. 4-19).
3	•	Water Drain Cock	Check that water drain cock works freely and no damage is visible. Replace a defective drain cock (para 4-19).
4	•	Tank	Inspect tank for rust. Clean and repaint exposed surfaces.

SECTION IV. UNIT TROUBLESHOOTING

Paragraph		Page
4-10	General.....	4-5
4-11	Unit Troubleshooting Procedures	4-5

4-10. General. This section contains troubleshooting procedures to determine the probable cause of observed equipment malfunctions. Test or inspections are provided to isolate the faulty component and corrective actions are provided to eliminate the malfunction.

4-11. Unit Troubleshooting Procedures. Refer to the symptom index to locate the troubleshooting procedure for the observed malfunction. The table lists the common malfunctions that may occur during the operation or maintenance of the filter/separator. Perform the tests or inspections, and the recommended corrective action in the order listed in the troubleshooting table. If the malfunction is corrected by a specific corrective action, do not continue with the remaining steps, if any, of the troubleshooting procedure. If the malfunction is not corrected by the listed corrective actions notify your supervisor.

SYMPTOM INDEX

Symptom	Page
Contaminated fuel at nozzle.....	4-6
No fuel delivery	4-6
General fuel leakage.....	4-6
Sudden increase in pressure differential.....	4-6
Sudden decrease in pressure differential.....	4-7

Table 4-2. Unit Troubleshooting Procedures.

MALFUNCTION	TEST OR INSPECTION	CORRECTIVE ACTION
1. CONTAMINATED FUEL.	Remove unit cover and inspect canister and filter elements for damage (para. 4-18 and 4-19).	Replace filter elements (para. 4-18).
2. NO FUEL DELIVERY.	Check to see if pumping unit is operating properly.	If pumping unit is not operating properly, refer to applicable technical manual.
3. GENERAL FUEL LEAKAGE.	Step 1. Check gaskets and/or seals.	Replace if damaged (para. 4-14).
	Step 2. Check lines and fittings for tightness.	Tighten lines and fittings or replace as needed (para. 4-19).
	Step 3. Check for cracks or breaks in tank shell.	Replace a cracked or damaged tank (para. 4-15).
4. SUDDEN INCREASE IN PRESSURE DIFFERENTIAL.	Step 1. Check to see if lines to differential pressure gage are clogged.	Unclog lines (para. 4-19).
	Step 2. Filter elements dirty.	Replace filter elements (para. 4-18).
	Step 3. Check differential pressure gage	Replace damaged differential pressure gage (para. 4-21).

Table 4-2. Unit Troubleshooting Procedures (cont).

MALFUNCTION	TEST OR INSPECTION	CORRECTIVE ACTION
5. SUDDEN DECREASE IN PRESSURE DIFFERENTIAL		
	STEP 1. Check for damaged differential pressure gage lines.	Replace damaged lines (para. 4-21).
	STEP 2. Check for damaged canisters.	Replace damaged canisters (para 4-17).
	STEP 3. Check for damaged differential pressure gage.	Replace damaged lines (para. 4-21).
	STEP 4. Check for damaged filter elements.	Replace damaged filters (para 4-18).

SECTION V. UNIT MAINTENANCE INSTRUCTIONS

Paragraph		Page
4-12	Cover.....	4-8
4-13	Tank.....	4-10
4-14	Frame	4-12
4-15	Manual Vent Valve.....	4-14
4-16	Coupling Gasket	4-16
4-17	Canisters.....	4-18
4-18	Elements.....	4-20
4-19	Valves, Lines, and Fittings	4-22
4-20	Sight Gage	4-27
4-21	Differential Pressure Gage	4-28
4-22	Grounding Rod Assembly.....	4-30
4-23	Water Detector Kit	4-34

4-12. Cover.

This task covers: Replace

INITIAL SETUP**Tools:**

General Mechanic's Tool Kit (Item 1, Appendix B)

Materials/Parts:

Glove, Rubber (Item 2, Appendix E)

Goggles (Item 3, Appendix E)

Silicone Compound (Item 6, Appendix E)

Replace. (figure 4-3)**WARNING**

Do not smoke or use open flame in vicinity of filter/separator. Use protective equipment to prevent skin and eye contact with fuel.

- (1) Remove manual vent valve (1).
- (2) Remove two nuts (2), washers (3), and bolts (4) and coupling (5).
- (3) Remove cover (6) and coupling gasket (7).
- (4) Inspect coupling gasket (7) and replace if ripped or otherwise damaged.
- (5) Apply silicone compound to coupling gasket (7).
- (6) Install coupling gasket (7), cover (6), and coupling (5), and secure with two screws (4), washers (3) and nuts (2).
- (7) Install manual vent valve (1).

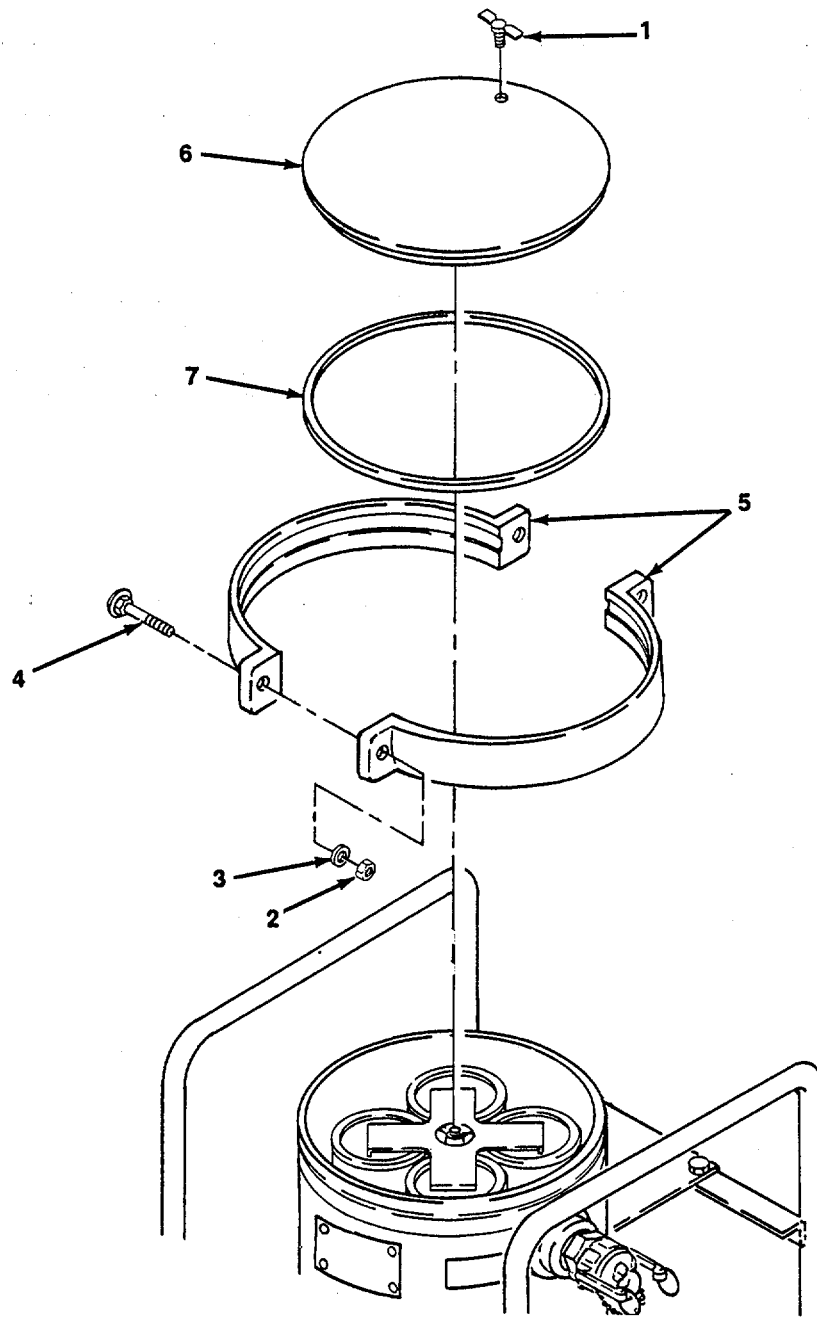

Figure 4-3. Cover, Replace.

4-13. Manual Vent Valve.

This task covers: **Replace**

INITIAL SETUP

Tools:

General Mechanic's Tool Kit (Item 1, Appendix B)

Replace. (figure 4-4)

- (1) Remove manual vent valve (1) from cover (2).
- (2) Install manual vent valve (1) on cover.

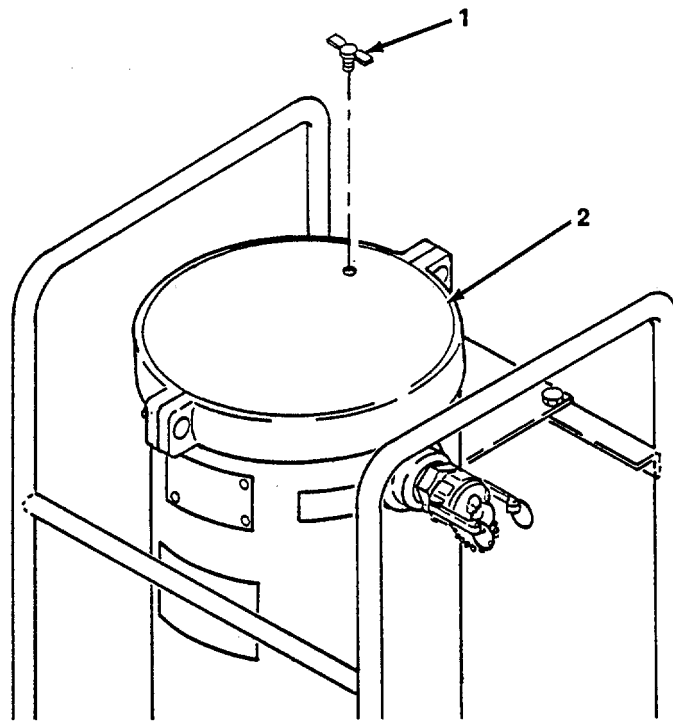

Figure 4-4. Manual Vent Valve, Replace.

4-14. Coupling Gasket.

This task covers: **Replace**

INITIAL SETUP**Tools: Materials/Parts:**

General Mechanic's Tool Kit (Item 1, Appendix B)	Gloves, Rubber (Item 2, Appendix E)
	Goggles (Item 3, Appendix E)
	Silicone Compound (Item 6, Appendix E)

Replace. (figure 4-5)

WARNING

Do not smoke or use open flame in vicinity of filter/separator. Use protective equipment to prevent skin and eye contact with fuel.

- (1) Remove two nuts (1), washers (2), and bolts (3) and remove coupling (4).
- (2) Remove cover (5) and coupling gasket (6).
- (3) Apply silicone compound to new coupling gasket (6).
- (4) Install coupling gasket (6) onto cover (5).
- (5) Install cover (5) with coupling gasket (6).
- (6) Install coupling (4) and secure with two screws (3), washers (2), and nuts (1).

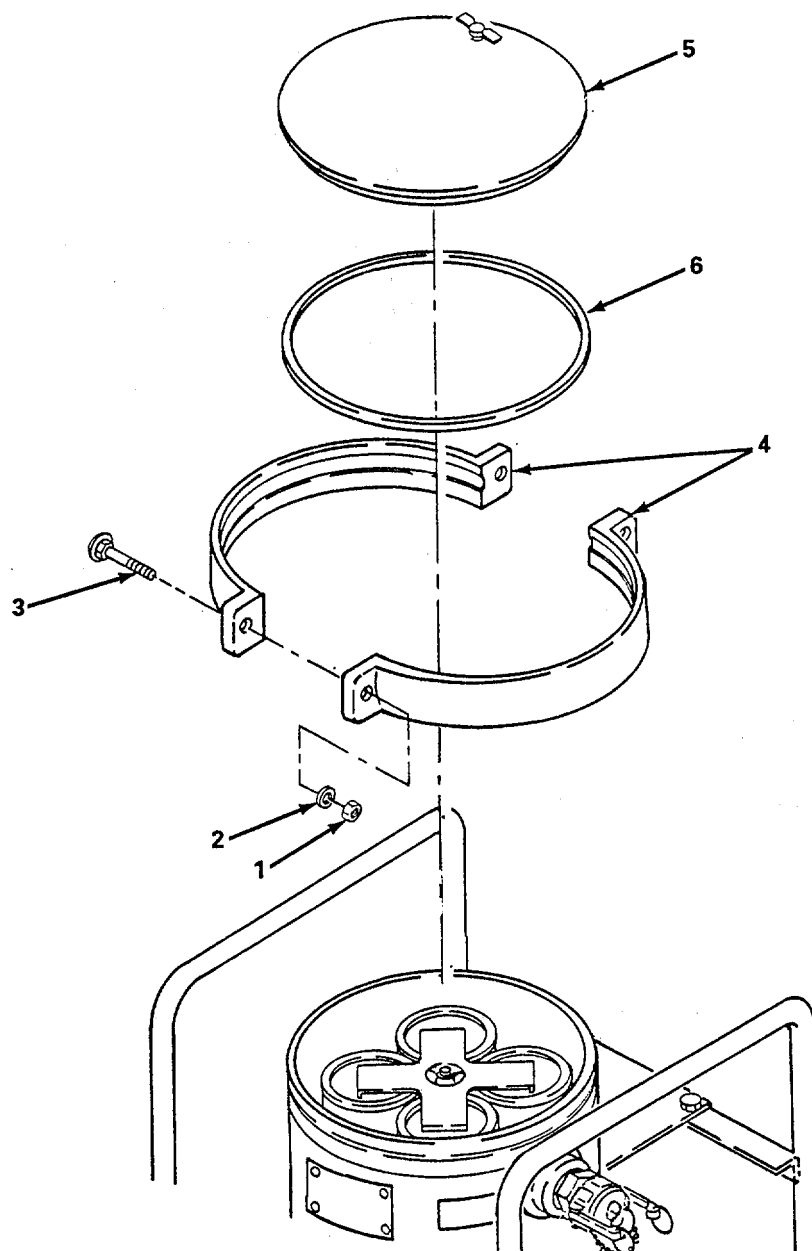

Figure 4-5. Coupling Gasket, Replace.

4-15. Tank.

This task covers: Replace

INITIAL SETUP**Tools:**

General Mechanic's Tool Kit (Item 1, Appendix B)
Grounding rod removed (para. 3-6)

Materials/Parts:

Lockwashers

Equipment Condition:

Valves lines and fittings removed (para. 4-19)

Sight gage removed (para. 4-20)

Differential pressure gage removed (para 4-21)

Canisters removed (para. 4-17)

Replace. (figure 4-6)

- (1) Loosen nut (1) and remove rod (2).
- (2) Remove two bolts (3), washers (4), lockwashers (5), and nuts (6).
- (3) Remove four bolts (7), washers (8), lockwashers (9) and nuts (10) and remove tank (11).

NOTE

Step 4 does not apply to model 13217E7140.

- (4) Install tank (11) on frame (12).
- (5) Install rod (2) and tighten nut (1).
- (6) Install four bolts (7), washers (8), lockwashers (9) and nuts (10).
- (7) Install two bolts (3), washers (4), lockwashers (5) and nuts (6).
- (8) Install differential pressure gage (para. 4-21).
- (9) Install sight gage (para. 4-20).
- (10) Install valves and fittings (para. 4-19).
- (11) Install canisters (para. 4-17).
- (12) Install grounding rod (para. 3-6).

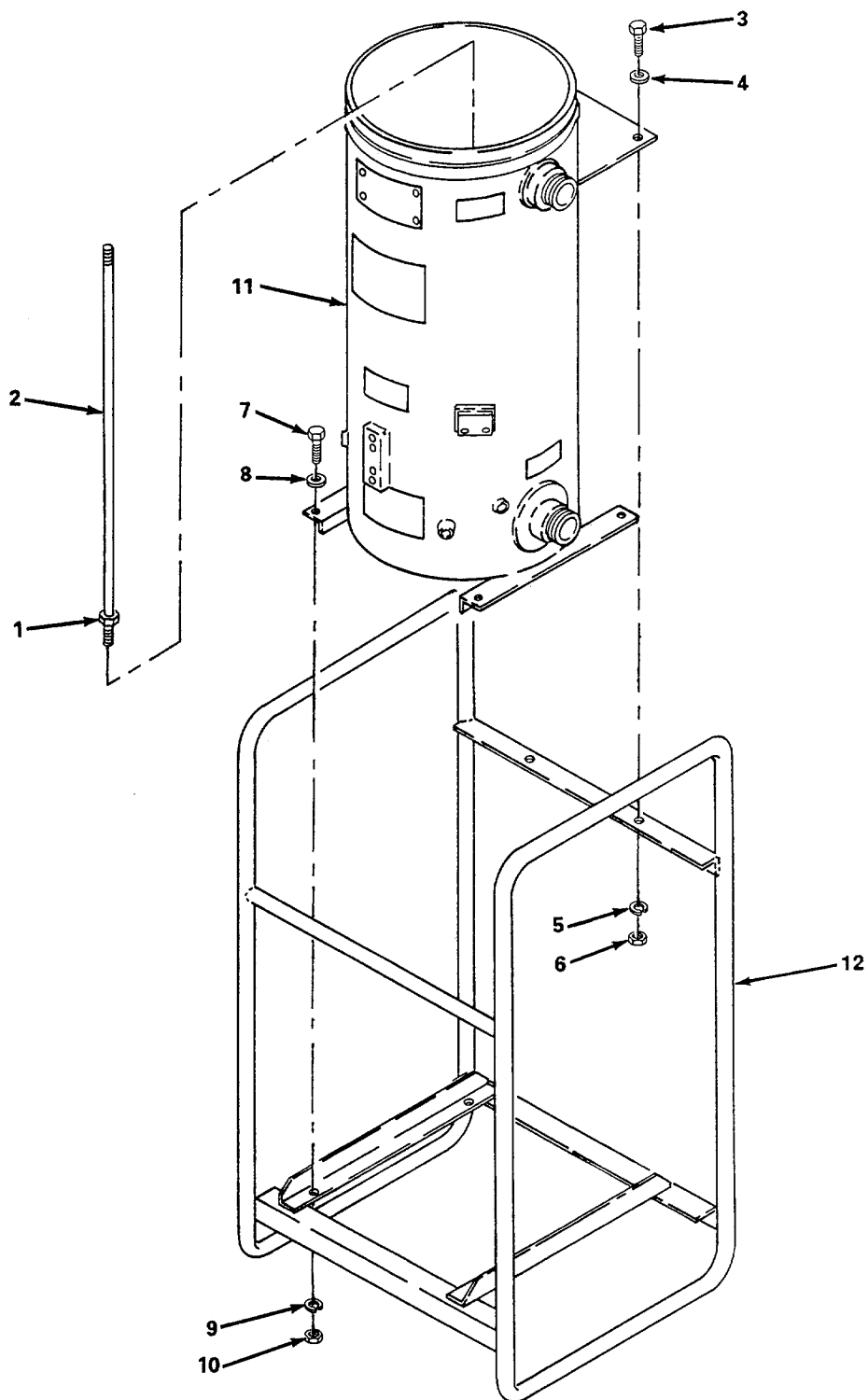

Figure 4-6. Tank, Replace.

4-16. Frame.

This task covers: Replace

INITIAL SETUP*Tools:*

General Mechanic's Tool Kit (Item 1, Appendix B)

Materials/Parts:

Lockwashers (Appendix F)

NOTE

This task does not apply to model 13217E7140.

Replace. (figure 4-7)

- (1) Remove two bolts (1), washers (2), lockwashers (3), and nuts (4).

NOTE

Rotate tank 90° to remove from frame.

- (2) Remove four bolts (5), washers (6), lockwashers (7) and nuts (8) and remove tank (9) from frame (10).
- (3) Install tank (9) in frame (10).
- (4) Install four bolts (5), washers (6), lockwashers (7) and nuts (8).
- (5) Install two bolts (1), washers (2), lockwashers (3) and nuts (4).

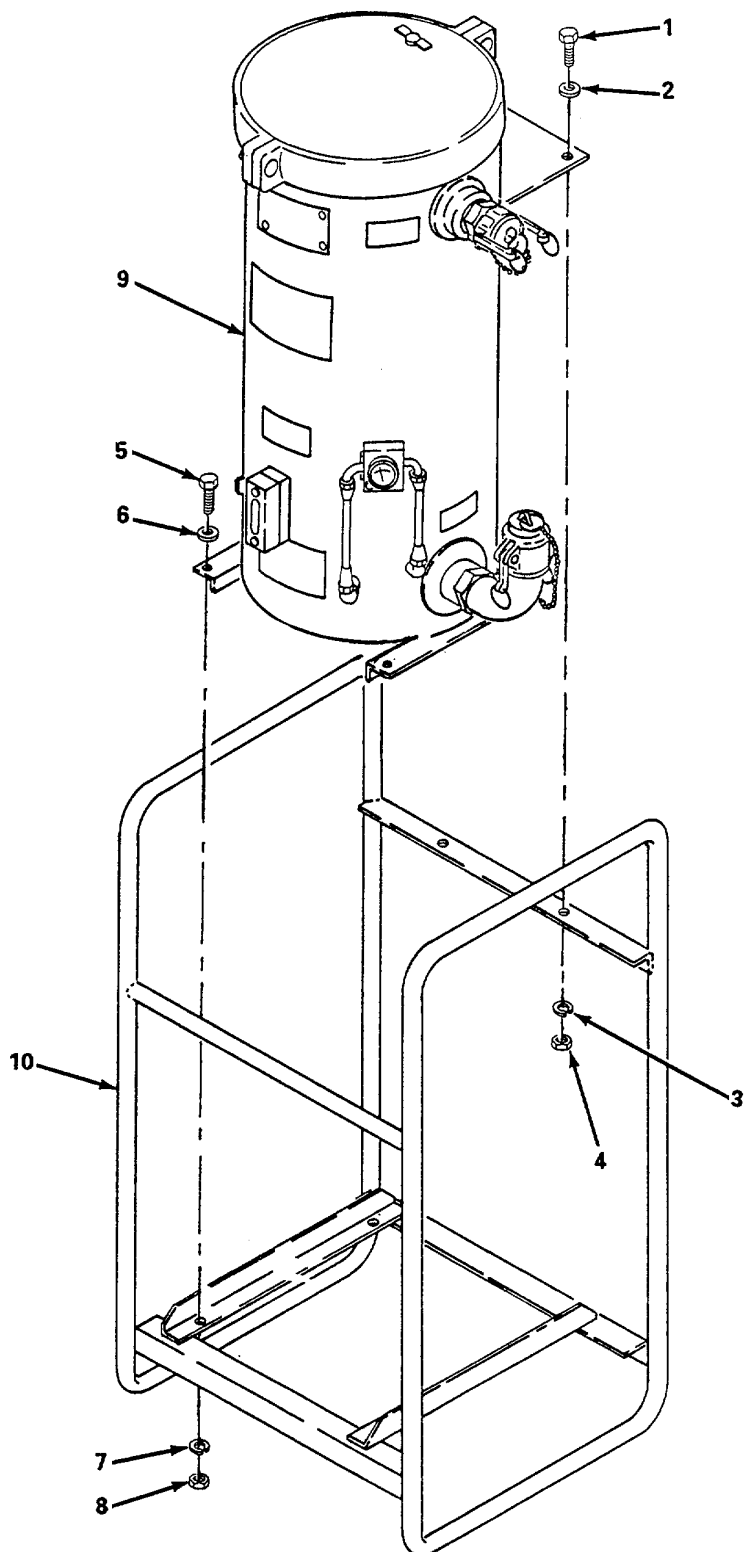

Figure 4-7. Frame, Replace.

4-17. Canisters.

 This task covers: Replace

INITIAL SETUP*Tools:*

General Mechanic's Tool Kit (Item 1, Appendix B)

Materials/Parts:

Gloves, Rubber (Item 1, Appendix E)

Goggles, Safety (Item 3, Appendix E)

Materials/Parts (cont)

Solvent, Dry Cleaning (Item 1, Appendix E)

Rags, Wiping (Item 4, Appendix E)

Silicone Compound (Item 5, Appendix E)

Lockwashers (Appendix F)

Replace. (figure 4-8)

WARNING

Do not smoke or use open flame in vicinity of filter/separator. Use protective equipment to prevent skin and eye contact with fuel.

- (1) Remove two nuts (1), washers (2) and bolts (3) and remove coupling (4), cover (5) and coupling gasket (6).
- (2) Remove wing nut (7) and lockwasher (8) and remove retainer (9).
- (3) Loosen thumb screw (10) and remove clamp band (11).

WARNING

The toxic effects of some fuel additives are potentially dangerous to personnel and property. Avoid repeated or prolonged skin contact. Use rubber fuel resistant gloves when replacing elements.

- (4) Remove four canisters (12) with elements (13).
- (5) Remove four elements (13) from canisters (12).

WARNING

Dry cleaning solvent, PD-680, used to clean parts is potentially dangerous to personnel and property. Avoid repeated or prolonged skin contact. Do not use near open flame or excessive heat. Flash point of solvent is 100-138°F (38-60°C).

- (6) Clean canisters (12) with dry cleaning solvent and dry thoroughly.
- (7) Inspect canisters (12) and replace if screen is torn or canisters (12) are bent, dented, or otherwise damaged.
- (8) Apply silicone compound to O-ring on each end of element.
- (9) Install four elements (13) in tank (14).

- (10) Install four canisters (12), over elements (13).
- (11) Install band clamp (11) and tighten thumbscrew (10).
- (12) Install retainer (9) and secure with wing nut (7) and lockwasher (8).
- (13) Apply silicone compound to coupling gasket (6).
- (14) Install coupling gasket (6) on cover (5)

NOTE

Install cover with vent valve to rear of filter/separator.

- (15) Install coupling gasket (6), cover (5), and coupling (4) and secure with two bolts (3), washers (2) and nuts (1).

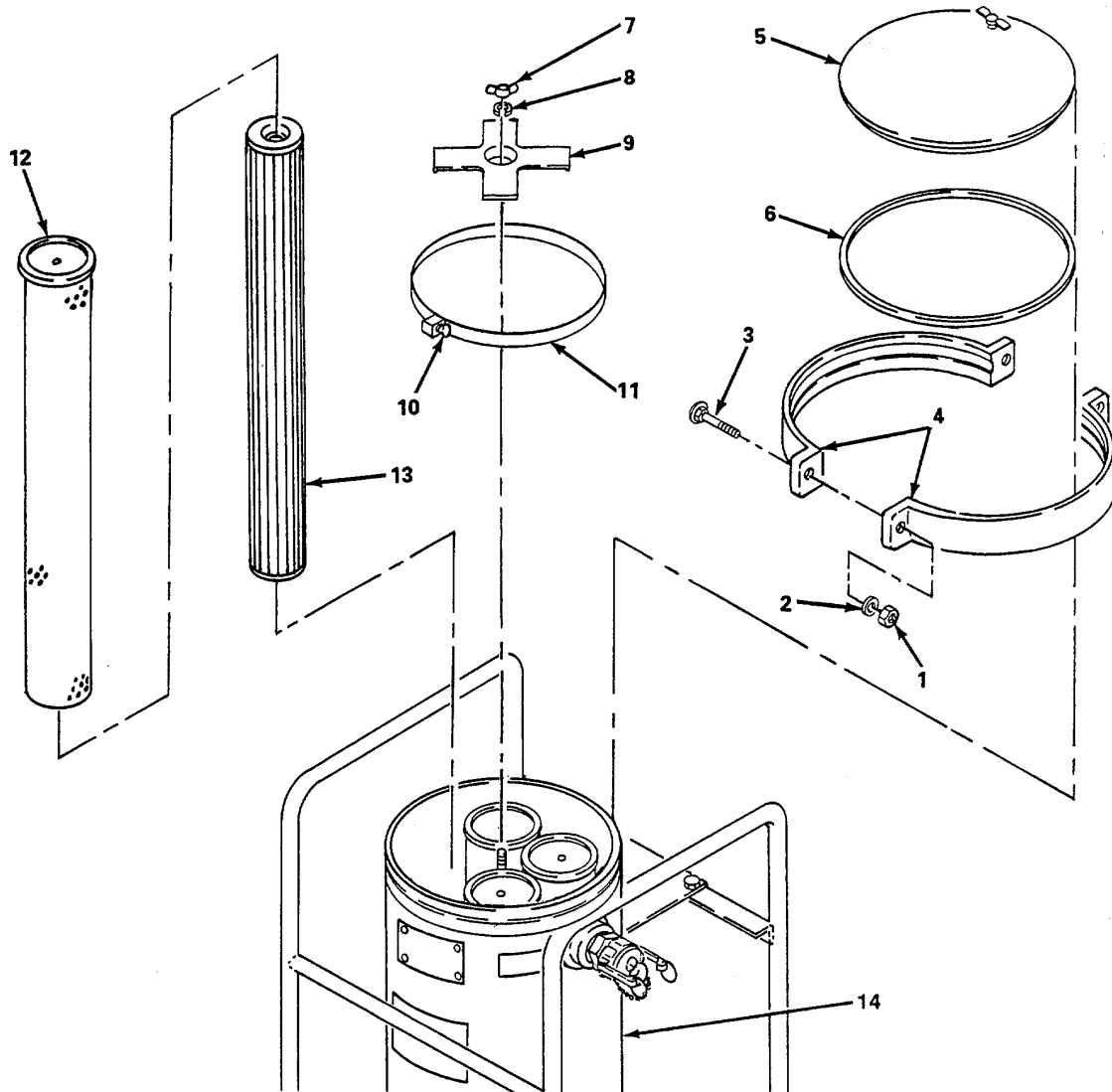

Figure 4-8. Canister, Replace.

4-18. Elements.

This task covers: Replace

INITIAL SETUP*Tools:*

General Mechanic's Tool Kit (Item 1, Appendix B)

Materials/Parts:

Gloves, Rubber (Item 2, Appendix E)
Goggles (Item 3, Appendix E)
Rags, Wiping (Item 4, Appendix E)
Silicone Compound (Item 6, Appendix E)

Replace. (figure 4-9)

WARNING

Do not smoke or use open flame in vicinity of filter/separator. Use protective equipment to prevent skin and eye contact with fuel.

- (1) Remove two nuts (1), washers (2) and bolts (3) and remove coupling (4), cover (5) and coupling gasket (6).
- (2) Remove wing nut (7) and lockwasher (8) and remove retainer (9).
- (3) Loosen thumb screw (10) and remove band clamp (11).

WARNING

The toxic effects of some fuel additives are potentially dangerous to personnel and property. Avoid repeated or prolonged skin contact. Use rubber fuel resistant gloves when replacing elements.

- (4) Remove four canisters (12) with elements (13).
- (5) Remove four elements (13) from canisters (12).
- (6) Apply silicone compound to O-ring on each end of element.
- (7) Install four elements (13) in tank (14).
- (8) Install four canisters (12) over elements (13).
- (9) Install clamp band (11) and tighten thumb screw (10).
- (10) Install retainer (9) and secure with wing nut (7) and lockwasher (8).
- (11) Apply silicone compound to coupling gasket (6).

NOTE

Install cover with vent valve to rear of filter/separator.

(12) Install coupling gasket (6) on cover (5).

(13) Install coupling gasket (6), cover (5), coupling (4) and secure with two bolts (3), washers (2), and nuts (1).

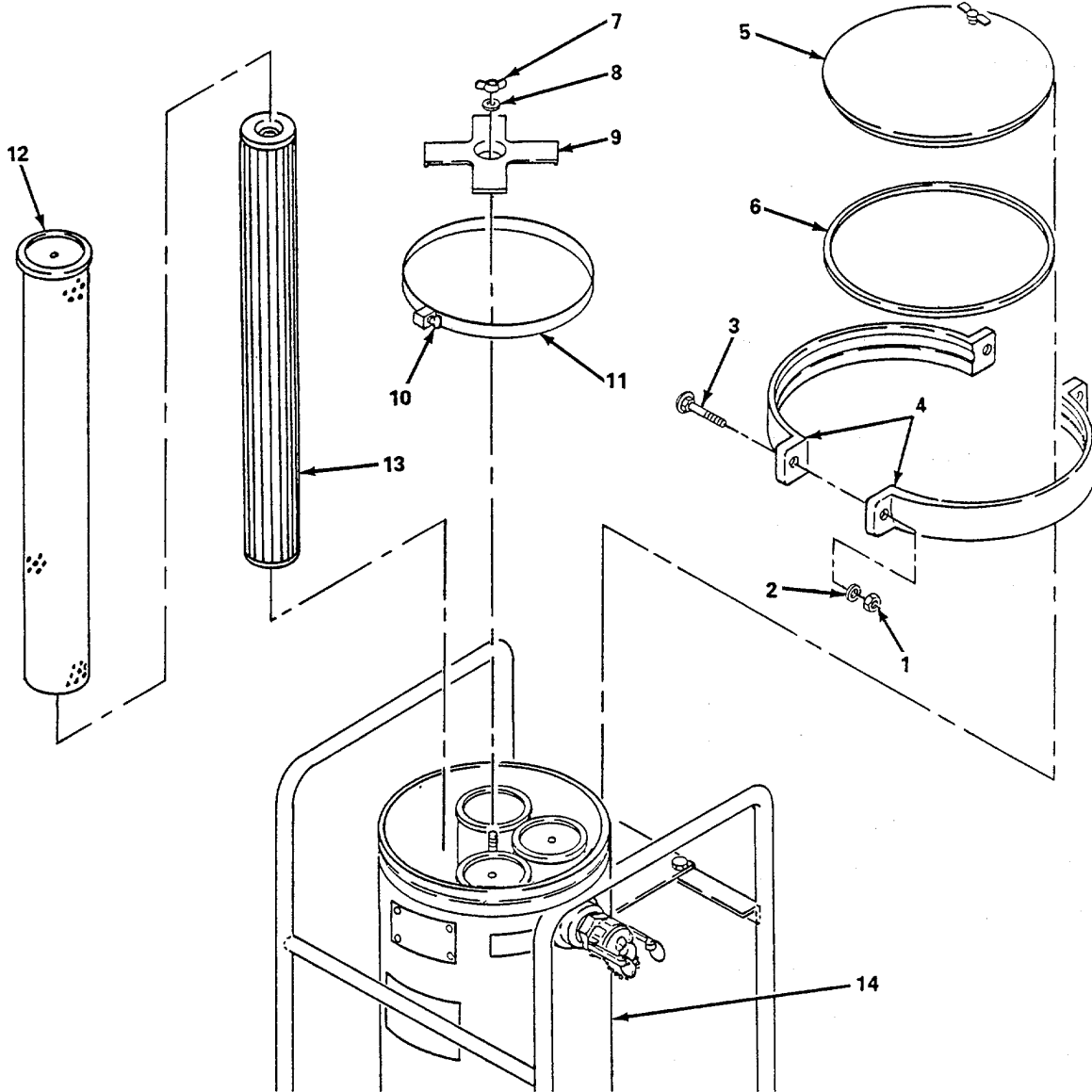

Figure 4-9. Elements, Replace.

4-19. Valves, Lines, and Fittings.

This task covers: Replace

INITIAL SETUP

Tools:

Materials/Parts:

General Mechanic's Tool Kit (Item 1, Appendix B)

Sealing Compound (Item 5, Appendix E)

Replace.

- (1) *Tube assembly.* (figure 4-10)
 - (a) Loosen two coupling nuts (1) and remove tube assembly (2).
 - (b) Remove elbow (3).
 - (c) Apply sealing compound to threads on elbow (3).
 - (d) Install elbow (3).
 - (e) Install tube assembly (2) and tighten two coupling nuts (1).

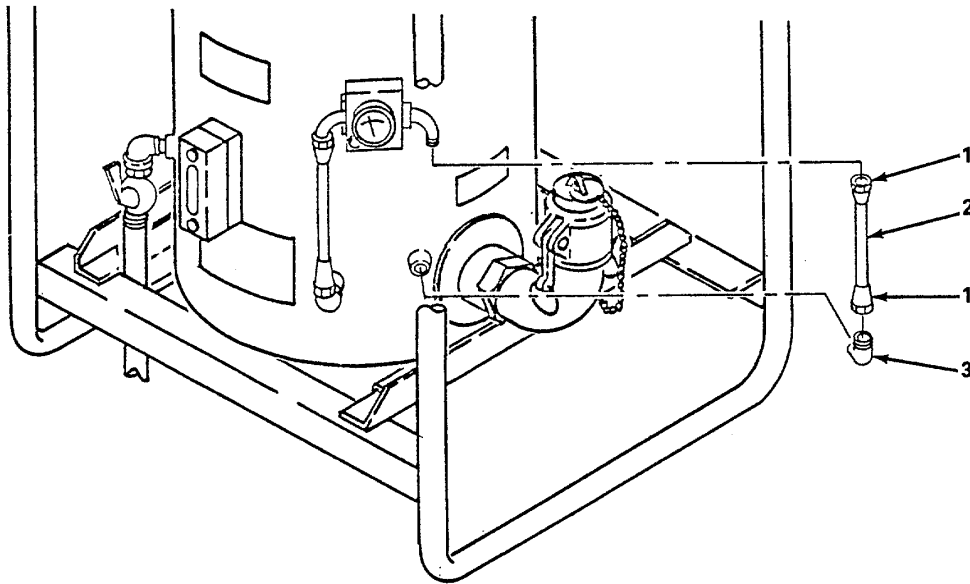

Figure 4-10. Tube Assembly, Replace.

- (2) *Coupling half quick disconnect (inlet).* (figure 4-11)
 - (a) Remove dust plug (1).
 - (b) Remove coupling half quick disconnect (2).
 - (c) Apply sealing compound to threads on quick disconnect (2).
 - (d) Install coupling half quick disconnect (2).
 - (e) Install dust plug (1).

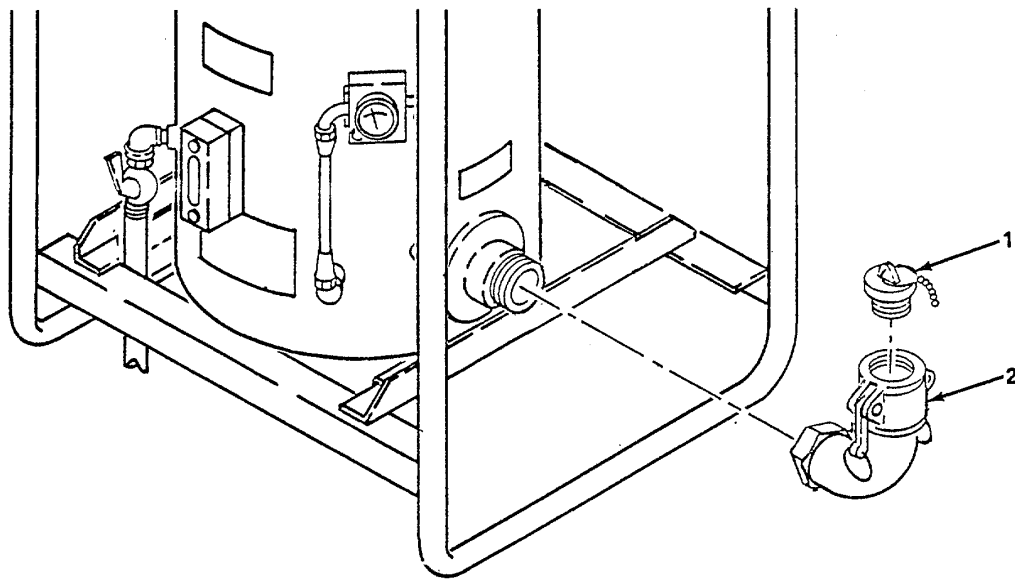

Figure 4-11. *Coupling Half Quick Disconnect (Inlet), Replace.*

4-19. Valves, Lines, and Fittings (cont).

- (3) *Coupling half quick disconnect (outlet).* (figure 4-12)
- (a) Remove dust cap (1).
 - (b) Remove coupling half quick disconnect (2).
 - (c) Apply sealing compound to threads on quick disconnect (2).
 - (d) Install coupling half quick disconnect (2).
 - (e) Install dust cap (1).

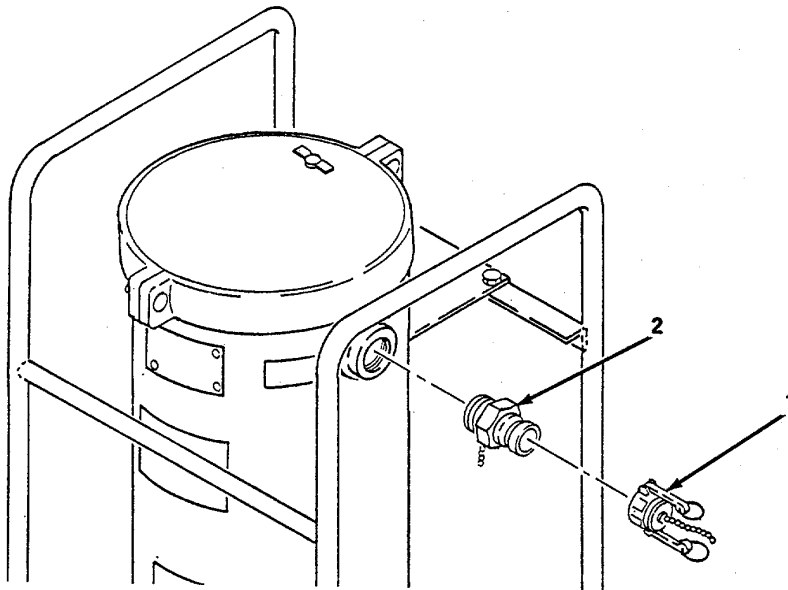

Figure 4-12. *Coupling Half Quick Disconnect (Outlet), Replace.*

- (4) *Water drain cock.* (figure 4-13)
- (a) Loosen clamp (1) and remove drain hose (2).
 - (b) Remove water drain cock (3) from elbow (4).
 - (c) Remove elbow (4) from tank (5).
 - (d) Inspect elbow (4) and replace if threads are stripped or elbow is otherwise damaged.
 - (e) Apply sealing compound to all pipe threads.
 - (f) Install elbow (4) on tank (5).
 - (g) Install water drain cock (3) into elbow (4).
 - (h) Install drain hose (2) and secure with clamp (1).

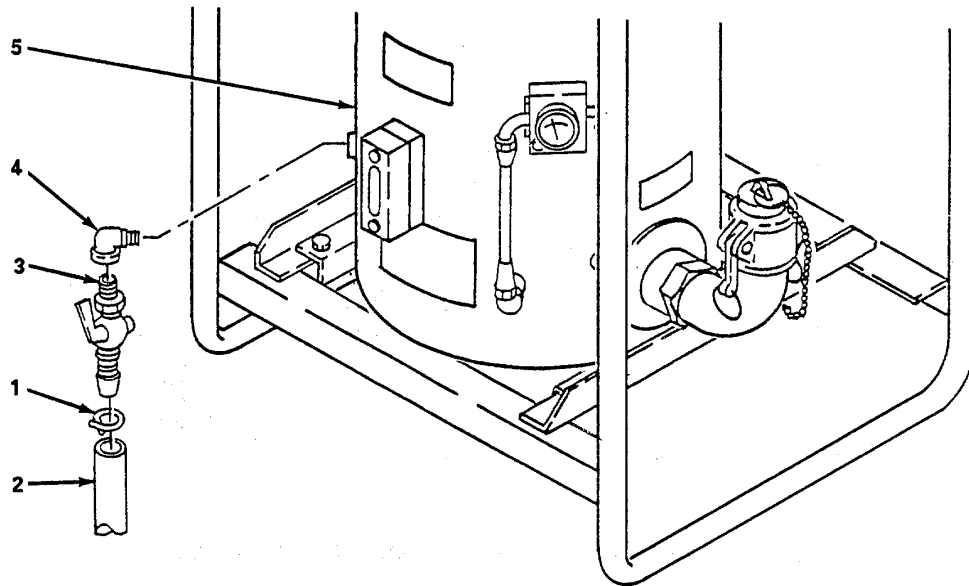

Figure 4-13. *Drain Cock, Replace.*

4-19. Valves, Lines, and Fittings (cont).

- (5) *Drain hose.* (figure 4-14)
- (a) Loosen clamp (1) and remove drain hose (2).
 - (b) Refer to appendix G, and make drain hose (2).
 - (c) Install drain hose (2) and secure with clamp (1)

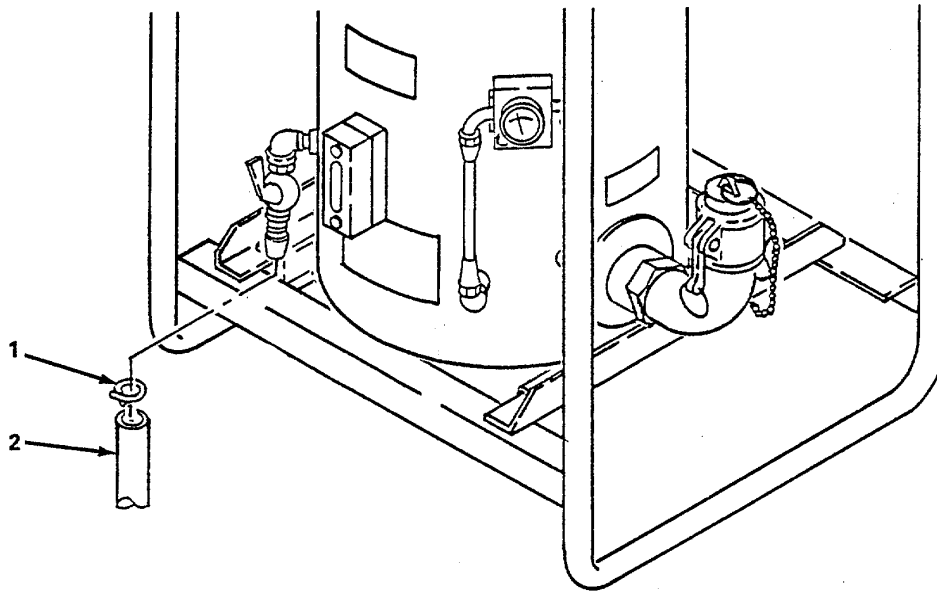

Figure 4-14. Drain Hose, Replace.

4-20. Sight Gauge.

This task covers: Replace

INITIAL SETUP*Tools:*

General Mechanic's Tool Kit (Item 1, Appendix B)

Materials/Parts:

Lockwashers (Appendix F)
Gasket, Water Level Sight Gauge (Appendix F)

Replace. (figure 4-15)

- (1) Remove two screws (1), lockwashers (2), and washers (3) and remove sight Gauge (4), ball (5) and gasket (6).
- (2) Ensure gasket surfaces are clean and old gasket material completely removed.
- (3) Install gasket (6), ball (5), and sight Gauge (4) and secure with two screws (1), lockwashers (2), and washers (3).

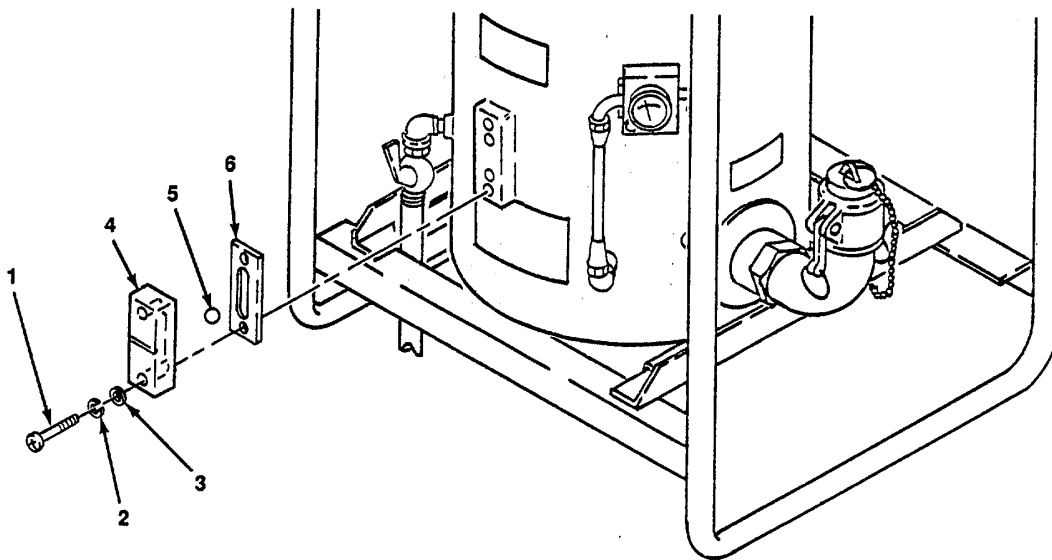

Figure 4-15. Sight Gauge, Replace.

4-21. Differential Pressure Gauge.

This task covers: Replace

INITIAL SETUP*Tools:*

General Mechanic's Tool Kit (Item 1, Appendix B)

Materials/Parts:

Lockwashers (Appendix F)
Sealing Compound (Item 5, Appendix E)

Replace. (figure 4-16)

- (1) Loosen two coupling nuts (1).
- (2) Remove two screws (2), washers (3), and lockwashers (4) and remove differential pressure gauge (5).
- (3) Remove two elbows (6) from differential pressure gauge (5).
- (4) Apply sealing compound to threads on elbows (6).
- (5) Install two elbows (6) and ensure they point down towards lines (7).
- (6) Install differential pressure gauge (5) and secure with two screws (2), washers (3) and lockwashers (4).
- (7) Tighten two coupling nuts (1).

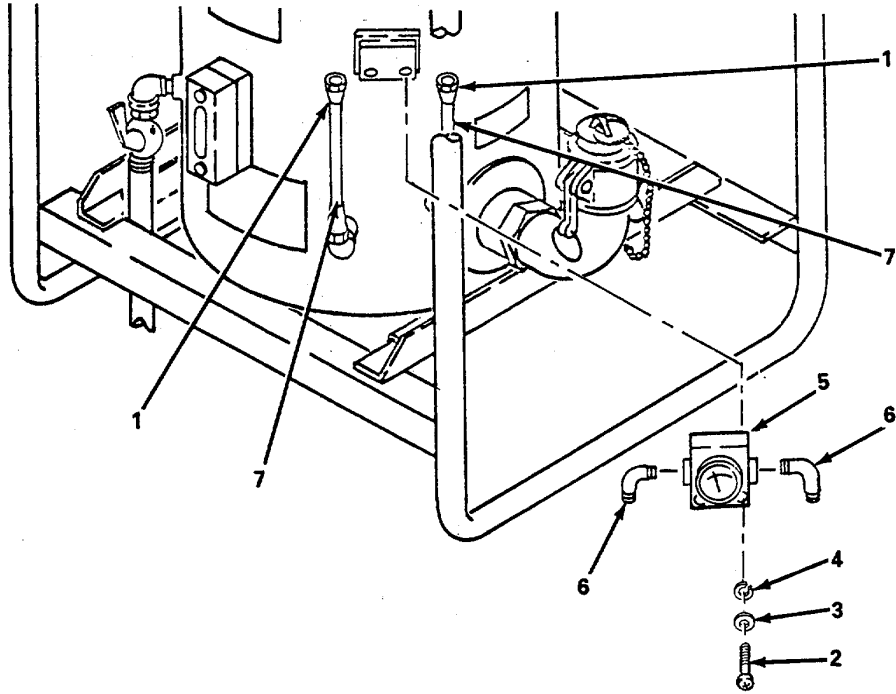

Figure 4-16. Differential Pressure Gauge, Replace.

4-22. Grounding Rod Assembly.

This task covers: a. Repair b. Replace

INITIAL SETUP

Tools:

Materials/Parts:

General Mechanic's Tool Kit (Item 1, Appendix B)

Locknut (Appendix F)

a. Repair. (figure 4-17)

- (1) Loosen screw (1) and remove strap (2) from clamp (3).
- (2) Remove locknut (4) and screw (5) and remove clamp (3).
- (3) Remove grounding rods (6) from frame (7).
- (4) Loosen screw (8) and remove strap (2) and clamp (9) from grounding rods (6).
- (5) Inspect grounding rods (6) and replace if threads are stripped or rods (6) are bent or otherwise damaged.
- (6) Inspect strap (2) and replace if wires are frayed, broken or otherwise damaged.
- (7) Inspect clamps (3) and (9) and replace if cracked or otherwise damaged.
- (8) Install clamp (9) on rods (6), insert strap (2) in clamp (9) and tighten screw (8).
- (9) Install clamp (3) and secure with screw (5) and nut (4).
- (10) Install rods (6) on frame (7).
- (11) Install strap (2) in clamp (3) and tighten screw (1).

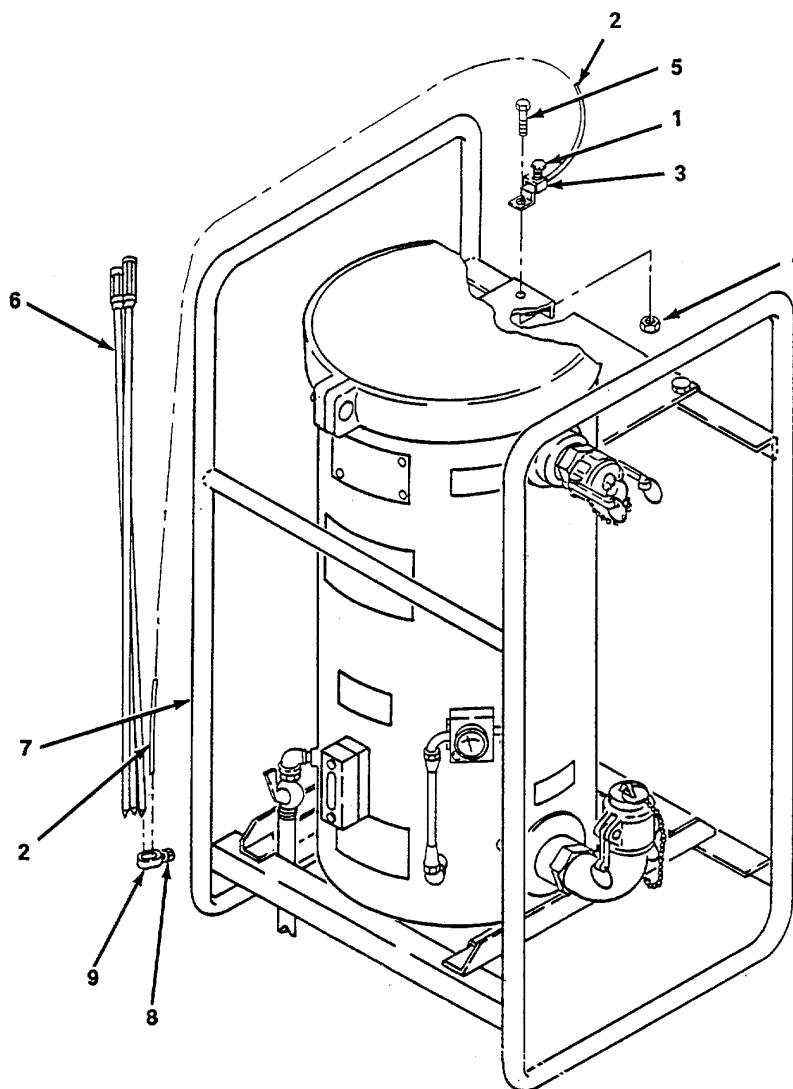

Figure 4-17. Grounding Rod Assembly, Repair.

4-22. Grounding Rod Assembly (cont).

b. Replace. (figure 4-18)

- (1) Remove screw (1) and locknut (2) securing clamp (3) and remove.
- (2) Remove grounding rods (4) from frame (5).
- (3) Position grounding rods (4) on frame (5).
- (4) Install clamp (3) and secure with screw (1) and nut (2).

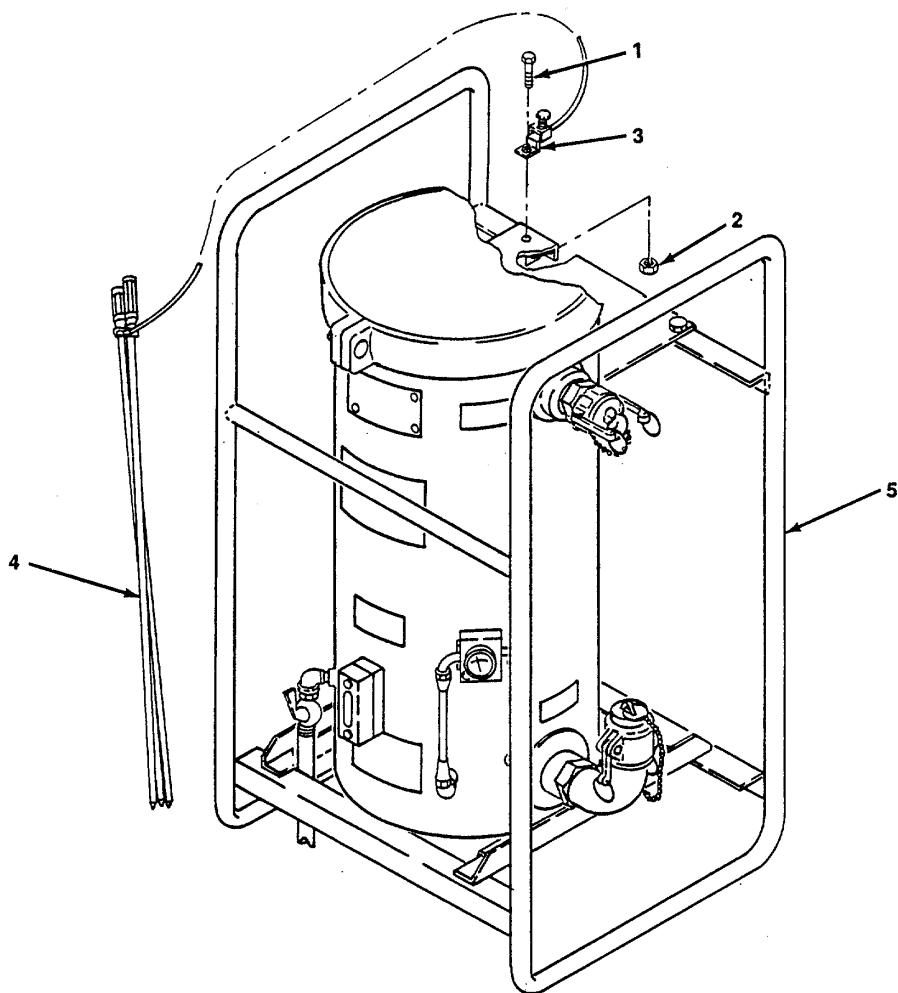

Figure 4-18. Grounding Rod Assembly, Replace.

MAINTENANCE OF WATER DETECTOR KIT

4-23. Repair of Adapter Assembly

This task covers: a. Disassembly b. Replace

INITIAL SETUPTools

General Mechanic Tool Kit (Appendix B, Section III, Item 4)
Vise
Wrench, Strap (Appendix B, Section III, Item 2)

Materials/Parts

Sealing Compound (Appendix E, Section II, Item 3)

Equipment Conditions

Adapter Assembly removed from Filter/Separator

DISASSEMBLY

- a. Clamp the adapter assembly securely in a vise and remove sampling probe (1).
- b. Pull cam handles on dust cap (2) out and remove dust cap.
- c. Pull cam handles of coupling half (3) out and remove dust plug (4).
- d. Unscrew coupling halves (3 and 5) from the adapter nipple (6).

REPAIR

Inspect components for damage and replace damaged parts. Check gasket (7) in coupling half (3) and replace if damaged or worn.

ASSEMBLY

- a. Be sure that there is a gasket (7) in coupling half (3).
- b. Clamp adapter nipple (6) in a vise. Apply sealing compound to threads of nipple and install coupling halves (3 and 5).
- c. Install dust plug in coupling half (3) and drive cams home to secure plug.
- d. Install dust cap (2) on coupling half (5) and drive cams home to secure cap.
- e. Apply sealing compound to threads of sampling probe (1) and screw probe into adapter nipple (6) making sure that the bevel of the probe is facing the end with female coupling half (3).

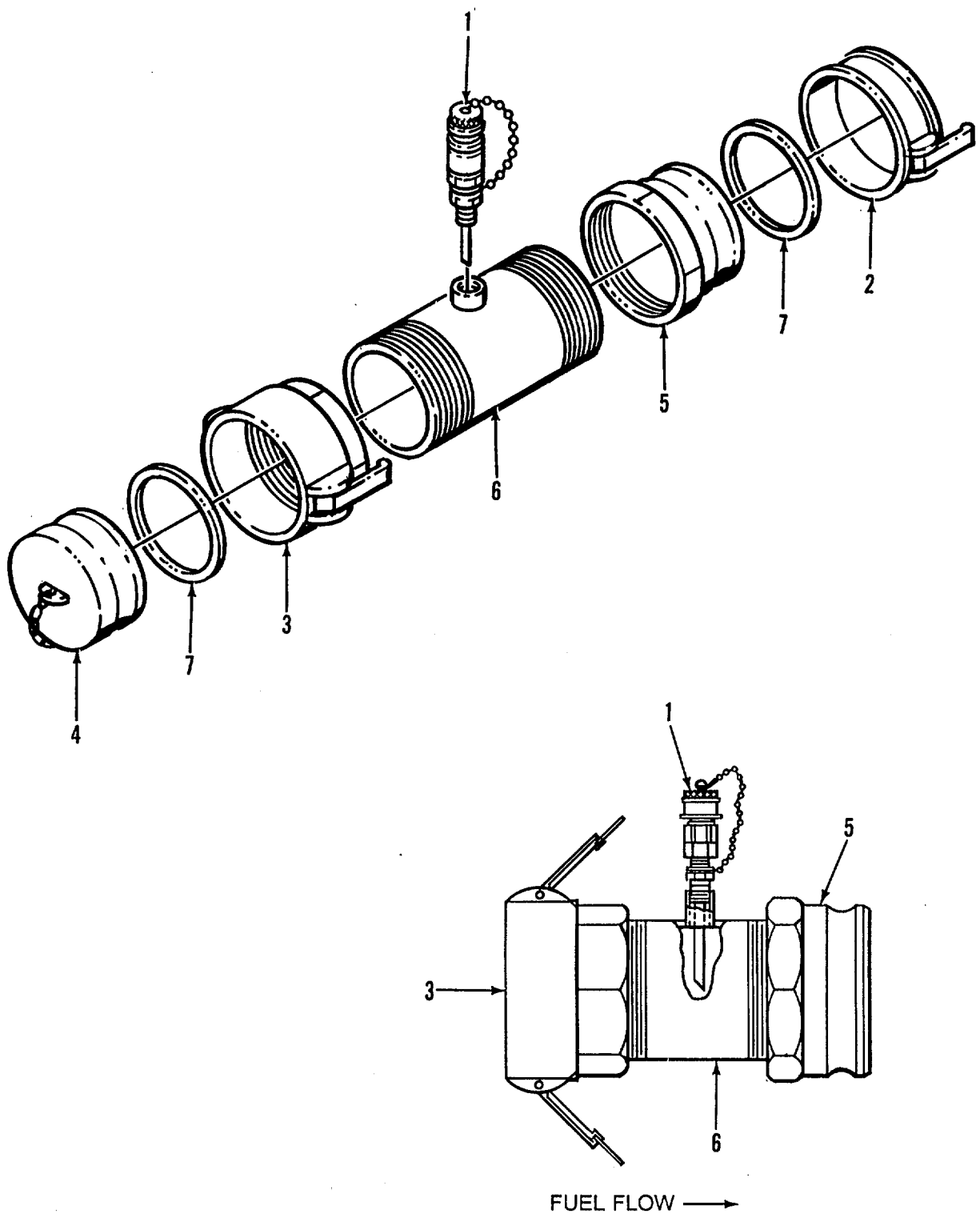

Figure 4-19 . Water Detector Kit, Repair

SECTION VI. PREPARATION FOR SHIPMENT OR STORAGE

Paragraph		Page
4-24	Short Term Storage.....	4-36
4-25	Intermediate Storage.....	4-36
4-26	Administrative Storage of Equipment	4-36
4-27	Preparation for Shipment	4-36

4-24. **Short Term Storage.** Store the filter/separator as follows:

- a. Isolate the filter/separator from the pipeline by closing the inlet blocking valve.
- b. Open the manual drain valve and drain the fuel in the tank into a suitable container.
- c. Disconnect inlet and outlet hoses from filter/separator.
- d. Disconnect ground rod.

WARNING

Two personnel are required to lift the filter/separator to avoid injury.

- e. Remove unit from pipeline.

4-25. **Intermediate Term Storage.** Refer to the following documents for information relative to storing the filter/separator.

- a. TM 38-230-1 Preservation and packing of military equipment.
- b. AR-750-1 Army Materiel Maintenance Policy and Retail Maintenance Operations.
- c. MIL-F-S2429 Packing of fuel separators.

4-26. **Administrative Storage.**

a. Placement of equipment in administrative storage should be for short periods of time when a shortage of maintenance effort exists. Items should be in mission readiness within 24 hours or within the time factors as determined by the directing authority. During the storage period appropriate maintenance records will be kept.

b. Before placing equipment in administrative storage, current Preventive Maintenance Checks and Services (PMCS) should be completed, shortcomings and deficiencies should be corrected, and all modification work orders (MWO's) should be applied.

c. Storage site selection. Inside storage is preferred for items selected for administrative storage. If inside storage is not available, trucks, vans, conex containers and other containers may be used.

4-27. **Preparation for Shipment.** Refer to the following documents.

- a. TM 38-230-1 Preservation and Packing of Military Equipment.
- b. MIL-F-52429 Packing of Fuel Separators.

APPENDIX A

REFERENCES

A-1. **Scope.** This appendix contains all forms, pamphlets and technical manuals referenced in this manual.

A-2. **Forms.**

Recommended changes to Publications.....	DA Form 2028
Recommended Changes to Publications.....	DA Form 2028-2
Equipment Inspection and Maintenance worksheet	DA Form 2404
Quality Deficiency Report (QDR).....	SF368
Report of Discrepancy (ROD).....	SF 364

A-3. **Pamphlets.**

The Army Maintenance Management System (TAMMS).....	DA Pam 738-750
Consolidated Index of Army Publication and Blank Forms.....	DA Pam 25-30

A-4. **Technical Manuals.**

Painting Instructions for Field Use	TM 43-0139
Procedures for Destruction of Equipment to Prevent Enemy Use	TM 750-244-3
Preservation and Packing of Military Equipment	TM 38-230-1

A-5. **Technical Bulletins.**

Hand Portable Fire Extinguishers Approved for Army Use.....	TB 5-4200-200-10
---	------------------

A-6. **Field Maintenance.**

First Aid for Soldiers.....	FM 21-11
-----------------------------	----------

A-7. **Army Regulations.**

Reporting of Item and Packaging Discrepancies.....	AR 735-11-2
Army Materiel Maintenance Policy and Retail Maintenance Operations.....	AR 750-1

A-1/(A-2 blank)

APPENDIX B. MAINTENANCE ALLOCATION CHART (MAC)

SECTION I. INTRODUCTION**B-1. GENERAL.**

a. This introduction (section I) provides a general explanation of all maintenance and repair functions authorized at various maintenance levels under the standard Army Maintenance System concept.

b. The Maintenance Allocation Chart (MAC) in section II designates overall authority and responsibility for the performance of maintenance functions on the identified end item or component. The application of the maintenance functions to the end item or component will be constant with the capacities and capabilities of the designated maintenance levels, which are shown in the MAC in column (4) as:

Unit - includes two subcolumns, C (operator/crew) and O (unit) maintenance.

Direct Support - includes an F subcolumn.

General Support - includes an H subcolumn.

Depot - includes an D subcolumn.

c. Section III lists the tools and test equipment (both special tools and common tools sets) required for each maintenance function as referenced from section II.

d. Section IV contains supplemental instructions and explanatory notes for a particular maintenance function.

B-2. MAINTENANCE FUNCTIONS. MAINTENANCE FUNCTIONS WILL BE LIMITED TO AND DEFINED AS FOLLOWS:

a. Inspect. To determine the serviceability of an item by comparing its physical, mechanical, and/or electrical characteristics with established standards through examination (i.e., by sight, sound, or feel).

b. Test. To verify serviceability by measuring the mechanical or electrical characteristics of an item and comparing those characteristics with prescribed standards.

c. Service. Operations required periodically to keep an item in proper operating condition, i.e., to clean (includes decontamination, when required), to preserve, to paint, or to replenish fuel, lubricants, chemical fluids, or gases.

d. Adjust. To maintain or regulate, within prescribed limits, by bringing into proper or exact position, or by setting the operating characteristics to specified parameters.

e. Aline. To adjust specified variable elements of an item to bring about optimum or desired performance.

f. Calibrate. To determine and cause corrections to be made or to be adjusted on instruments or test, measuring, and diagnostic equipment used in precision measurement. Consists of comparisons of two instruments, one of which is a certified standard of known accuracy, to detect and adjust any discrepancy in the accuracy of the instrument being compared.

g. Remove/Install. To remove and install the same item when required to perform service or other maintenance functions. Install may be the act of emplacing, seating, or fixing into position a spare, repair part, or module (component or assembly) in a manner to allow the proper functioning of an equipment or system.

h. Replace. To remove an unserviceable item and install a serviceable counterpart in its place. Replace is authorized by the MAC and is shown as the 3rd position code of the SMR code.

i. Repair. The application of maintenance services¹ including fault location/troubleshooting², removal/installation, and disassembly/assembly³ procedures, and maintenance actions⁴ to identify troubles and restore serviceability to an item by correcting specific damage, fault, malfunction, or failure in a part, subassembly, module (component or assembly), and item, or system.

j. Overhaul. That maintenance effort (service/action) prescribed to restore an item to a completely serviceable/operational condition as required by maintenance standards in appropriate technical publications (i.e., DMWR). Overhaul in normally the highest degree of maintenance performed by the Army. Overhaul does not normally return an item to like new condition.

k. Rebuild. Consists of those service/actions necessary for the restoration of unserviceable equipment to a like-new condition in accordance with original manufacturing standards. Rebuild is the highest degree of material maintenance applied to Army equipment. The rebuild operation includes the act of returning to zero those age measurements (hours, miles, etc.) considered in classifying Army equipment and components.

B-3. EXPLANATION OF COLUMNS IN THE MAC. SECTION II.

a. Column 1 - Group Number. Column 1 lists functional group code numbers, the purpose of which is to identify maintenance significant components, assemblies, subassemblies, and modules with the next higher assembly.

b. Column 2 - Component/Assembly. Column 2 contains the names of components, assemblies, subassemblies, and modules for which maintenance is authorized.

c. Column 3 - Maintenance Function. Column 3 lists the functions to be performed on the item listed in column 2. (For detailed explanation of these functions, see paragraph B-2.)

- C Operator or Crew
- O Unit Maintenance
- F Direct Support Maintenance
- H General Support Maintenance
- D Depot Maintenance

d. Column 4 Maintenance Category. Column 4 specifies, by the listing of a work time figure in the appropriate subcolumn(s), the category of maintenance authorized to perform the function listed in Column 3. This figure represents the active time required to perform that maintenance function at the indicated category of maintenance. If the number or complexity of the tasks within the listed maintenance function varies at different maintenance categories, appropriate work time figures will be shown for each category. The work time figure represents the average time required to restore an item (assembly, subassembly, component, module, end item, or system) to a serviceable condition under typical field operating conditions. This time includes preparation time (including any necessary disassembly/assembly time), troubleshooting/fault location time, and quality assurance/quality control time in addition to the time required to perform the specific tasks identified for the maintenance functions authorized in the maintenance allocation chart. The symbol designations for the various maintenance categories are as follows:

¹Service - Inspect, test, service, adjust, aline, calibrate, and/or replace

²Fault location/troubleshooting - The process of investigating and detecting the cause of equipment malfunctioning; the act of isolating a fault within a system or unit under test (UUT).

³Disassembly/assembly - The step-by-step breakdown (taking apart) of a spare/functional group coded item to the level of its least component, that is assigned as SMR code for the level of maintenance under consideration (i.e., identification as maintenance significant).

⁴Actions - Welding, grinding, riveting, straightening, facing, machining, and/or resurfacing.

e. Column 5- Tools and Equipment. Column 5 specifies, by code, those common tool sets (not individual tools) and special tools, TMDE, and support equipment required to perform the designated function.

f. Column 6 - Remarks. This column shall, when applicable, contain a letter code, in alphabetic order, which shall be keyed to the remarks contained in section IV.

B-4. EXPLANATION OF COLUMNS IN TOOL AND TEST EQUIPMENT REQUIREMENTS, SECTION III.

- a. Column 1 - Reference Code. The tool and test equipment reference code correlates with a code used in the MAC, section II, column 5.
- b. Column 2 - Maintenance Category. The lowest category of maintenance authorized to use the tool or test equipment.
- c. Column 3 - Nomenclature. Name or identification of the tool or test equipment.
- d. Column 4 - National Stock Number. The National stock number of the tool or test equipment.
- e. Column 5- Tool Number. The manufacturer's part number.

B-5. EXPLANATION OF COLUMNS IN REMARKS, SECTION IV.

- a. Column 1 - Reference Code. The code recorded in column 6, section II.
- b. Column 2 - Remarks. This column lists information pertinent to the maintenance function being performed as indicated in the MAC, section II.

SECTION II. MAINTENANCE ALLOCATION CHART

TM NUMBER

Section II MAINTENANCE ALLOCATION CHART

(1) GROUP NUMBER	(2) COMPONENT/ ASSEMBLY	(3) MAINTENANCE FUNCTION	(4) MAINTENANCE LEVEL					(5) TOOLS AND EQUIPMENT	(6) REMARKS
			C	O	F	H	D		
00	Filter/Separator Tank and Frame Assy	Inspect	0.2					A	
01		Replace		0.5			1		
0101	Manual Vent Valve	Inspect	0.2				1		
		Replace		0.5			1		
0102	Coupling Gasket	Inspect	0.2				1		
		Replace		0.5			1		
0103	Tank and Frame	Inspect	0.2				1		
		Replace		0.5			1		
0104	Canister	Inspect	0.2				1		
		Replace		0.5			1		
0105	Elements	Inspect	0.2				1		
		Replace		0.5			1		
02	Valves ,Lines, and Fittings	Inspect	0.2				1		
		Service	0.2				1		
03	Sight Gage and Differen- tial Pressure Gage	Replace		0.5			1		
		Inspect	0.2				1		
04	Grounding Rod Assy	Inspect	0.2				1		
		Repair		0.5			1		
		Replace		0.5			1		
05	Water Detector Kit	Inspect	0.2				1		
		Repair		0.8			1		
		Replace		0.7			1		

SECTION II. MAINTENANCE ALLOCATION CHART (cont).

0501	Adapter Assembly	Inspect Repair Replace	0.2	0.8 0.5			1,2,3 1,2	B B
0502	Sampling Probe	Inspect Replace	0.2 0.2				1	

SECTION III. TOOLS AND TEST EQUIPMENT REQUIREMENTS

TOOL OR TEST EQUIPMENT REF CODE	MAINTENANCE CATEGORY	NOMENCLATURE	NATIONAL/NATO STOCK NUMBER	TOOL NUMBER
1	O	General Mechanic's Tool Kit CL-N26	5180-00-017-7033	SC 5180-90-
2	O	Shop Equipment, Automotive Maintenance and Repair: Organizational Maintenance Common No. 1 Less Power	4910-00-754-0654	SC 4910CL-A 74
3	O	Wrench Pipe: Adj Jaw Style, 1-1/2 inch to 2-1/2 inch	5120-00-277-1462	SC 4910-95CL-A74

SECTION IV. REMARKS

REFERENCE CODE	REMARKS/NOTES
A	Service to the Filter/Separator consists of cleaning and replacing elements.
B	Repair by Replacing Defective Components.

APPENDIX C

COMPONENTS OF END ITEM AND BASIC ISSUE ITEMS LISTS

SECTION I. INTRODUCTION

C-1. Scope.

This appendix lists components of end item and basic issue items for the filter/separator to help you inventory items required for safe and efficient operation.

C-2. General.

The Components of End Item and Basic Issue Items Lists are divided into the following sections:

a. Section II. Components of End Item. This listing is for informational purposes only, and is not authority to requisition replacements. These items are part of the end item, but are removed and separately packaged for transportation or shipment. As part of the end item, these items must be with the end item whenever it is issued or transferred between property accounts. Illustrations are furnished to assist you in identifying the items.

b. Section III. Basic Issue Items. These are the minimum essential items required to place the filter/separator in operation, to operate it, and to perform emergency repairs. Although shipped separately packaged, BII must be with the filter/separator during operation and whenever it is transferred between property accounts. The illustrations will assist you with hard-to-identify items. This manual is your authority to request/requisition replacement BII, based on TOE/MTOE authorization of the end item.

C-3. Explanation of Columns.

The following provides an explanation of columns found in the tabular listings:

a. Column (1) - Illustration Number (Illus Number). This column indicates the number of the illustration in which the item is shown.

b. Column (2) - National Stock Number. Indicates the National stock number assigned to the item and will be used for requisitioning purposes.

c. Column (3) - Description. Indicates the Federal item name and, if required, a minimum description to identify and locate the item. The last line for each item indicates the Contractor and Government Entity (CAGE) Code (in parentheses) followed by the part number.

d. Column (4) - Unit of Measure (U/M). Indicates the measure used in performing the actual operational/maintenance function. This measure is expressed by a two-character alphabetical abbreviation (e.g., ea, in, pr).

e. Column (5) - Quantity required (QTY RQR). Indicates the quantity of the item authorized to be used with/on the equipment.

SECTION II. COMPONENTS OF END ITEM

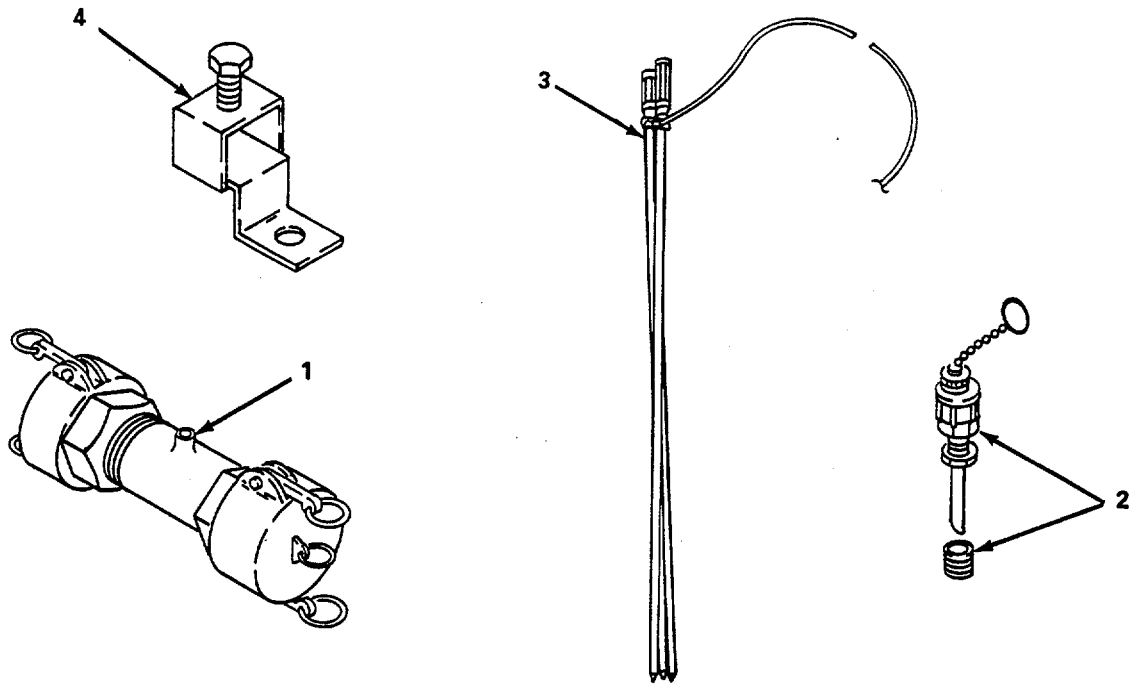

(1) Illus Number	(2) National Stock Number	(3) Description CAGE and Part Number	Usable On Code	(4) U/M	(5) Qty Rqr
1		Adapter, Water Detector Kit (97403) 13220E9406-3		ea	1
2		Probe Assembly, Water Detector Kit (97403) 13220E9914-3		ea	1
3	5975-00-878-3791	Rod, Grounding Assembly (81349) MIL-R-11461		ea	1
4	5999-01-032-4145	Clamp, Ground Cable (97403) 13217E9339		ea	1

SECTION III. BASIC ISSUE ITEMS

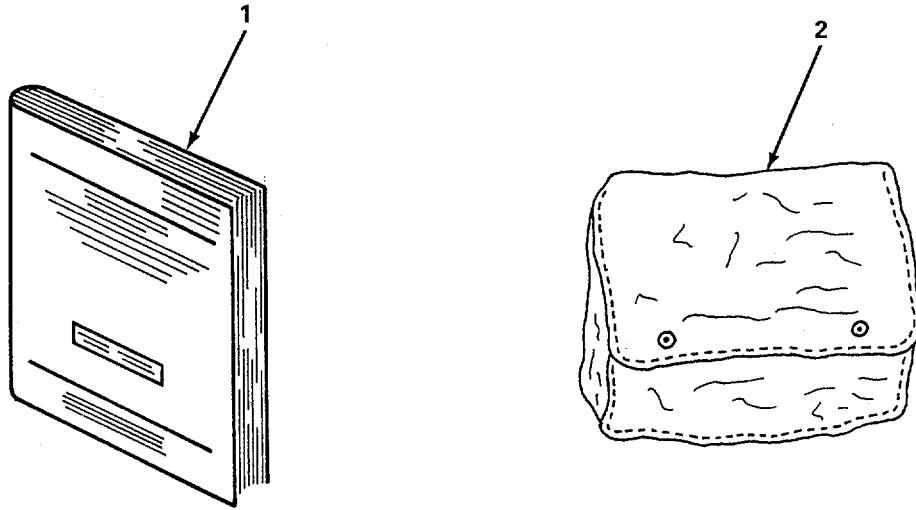

(1) Illus Number	(2) National Stock Number	(3) Description CAGE and Part Number	(4) Usable On Code U/M	(5) Qty Rqr
1		TM 5-4330-232-12&P, Operator and Unit Maintenance Manual, Repair Parts and Special Tools List, Filter/Separator Liquid Fuel, 50 GPM, NSN 4330-00-251-4381, NSN 4330-01-012-3313	ea	1
2	5220-00-559-9618	Case, Department of Army Technical Manual	ea	1

C-3/(C-4 blank)

APPENDIX D

ADDITIONAL AUTHORIZATION LIST

SECTION I. INTRODUCTION

D-1. Scope.

This appendix lists additional items you are authorized for the support of the filter/separator.

D-2. General.

This list identifies items that do not have to accompany the (filter/separator) and that do not have to be turned in with it. These items are all authorized to you by CTA, MTOE, TDA, or JTA.

D-3. Explanation of Listing.

National stock numbers, descriptions, and quantities are provided to help you identify and request the additional items you require to support this equipment. The items are listed in alphabetical sequence by item name under the type document (i.e., CTA, MTOE, TDA, or JTA) which authorizes the item(s) to you. (Enter portions of next three sentences, only if applicable.) If the item you require differs between serial numbers of the same model effective serial numbers are shown in the last line of the description. If item required differs for different models of this equipment, the model is shown under the "Usable on" heading in the description column.

SECTION II. ADDITIONAL AUTHORIZATION LIST

National Stock Number	Description	Usable Code	Qty U/M	Auth
6640-00-244-9478	Detector Kit, Automotive Aviation Fuel, Water, and Solid Contamination		ea	1

D-1/(D-2 blank)

APPENDIX E

EXPENDABLE/DURABLE SUPPLIES AND MATERIALS LIST

SECTION I. INTRODUCTION

E-1. Scope. This listing is for informational purposes only and is not authority to requisition the listed items. These items are authorized to you by CTA 50-970, Expendable/Durable Items (except medical, class V, repair parts, and heraldic items).

E-2. Explanation of Columns.

a. Column (1) - Item Number. This number is assigned to the entry in the listing and is referenced in the narrative instructions to identify the material (e.g., "Use cleaning compound, item 5, appendix C").

b. Column (2) - Level. This column identifies the lowest level of maintenance that requires the listed item.

- C - Operator/Crew
- O - Unit Maintenance
- F - Direct Support Maintenance
- H - General Support Maintenance

c. Column (3) - National Stock Number. This is the National stock number assigned to the item; use it to request or requisition the item.

d. Column (4) - Description. Indicates the Federal item name, and, if required, a description to identify the item. The last line for each item indicates the Contractor and Government Entity (CAGE) code in parentheses followed by the part number.

e. Column (5) - Unit of Measure (U/M). Indicates the measure used in performing the actual maintenance function. This measure is expressed by a two-character alphabetical abbreviation (e.g., EA, IN., PR). If the unit of measure differs from the unit of issue, requisition the lowest unit of issue that will satisfy your requirements.

Section II. EXPENDABLE/DURABLE SUPPLIES AND MATERIALS LIST

(1) Item number	(2) Level	(3) National stock number	(4) Description	(5) U/M
1	O	6850-00-281-1985	Cleaning Solvent, Fed. Spec. PD-680	gl
2	O		Gloves, Rubber	pr
3	O		Goggles, Safety	ea
4	O		Rag, Wiping 50 Lb (58536) A-A-531	ea
5	O		Sealing Compound, MIL-S-7916 (81349)	qt
6	O	6850-00-880-7616	Silicone Compound, MIL-S-8660 (81349)	qt

E-1/(E-2 blank)

**OPERATOR'S AND UNIT
MAINTENANCE REPAIR PARTS AND SPECIAL TOOLS LIST**

SECTION I. INTRODUCTION

1. SCOPE. This RPSTL lists and authorizes spares and repair parts; special tools; special test, measurement, and diagnostic equipment (TMDE); and other special support equipment required for performance of unit, direct support and general support maintenance of the Filter/Separator, 50 GPM Capacity. It authorizes the requisitioning, issue, and disposition of spares, repair parts and special tools as indicated by the source, maintenance and recoverability (SMR) codes.

2. GENERAL. In addition to this section, Introduction, this Repair Parts and Special Tools List is divided into the following sections:

a. Section II. Repair Parts List. A list of spares and repair parts authorized by this RPSTL for use in the performance of maintenance. This list also includes parts which must be removed for replacement of the authorized parts. Parts lists are composed of functional groups in ascending alphanumeric sequence, with the parts in each group listed in ascending figure and item number sequence. Bulk materials are listed in item name sequence. Repair parts kits are listed separately in functional groups in Section II. Repair parts for repairable special tools are also listed in this section. Items listed are shown in the associated illustration(s)/figure(s).

b. Section III. Special Tools List. A list of special tools, special TMDE, and other special support equipment authorized by this RPSTL (as indicated by Basis of Issue (BOI) information in DESCRIPTION AND USABLE ON CODE column) for the performance of maintenance.

c. Section IV. Cross-Reference Index. A list, in National Item Identification Number (NIIN) sequence, of all national stock numbered items appearing in the listing, followed by a list in alphanumeric sequence of all part numbers appearing in the listings. National stock numbers and part numbers are cross referenced to each illustration figure and item number appearance. The figure and item number index lists figure and item numbers in alphanumeric sequence and cross references NSN, CAGEC and part number.

3. EXPLANATION OF COLUMNS (SECTIONS II AND III).

a. ITEM NO. (Column (1)). Indicates the number used to identify items called out in the illustration.

b. SMR Code (Column (2)). The Source, Maintenance, and Recoverability (SMR) code is a 5-position code containing supply/requisitioning information, maintenance category authorization criteria, and disposition instruction, as shown in the following breakout:

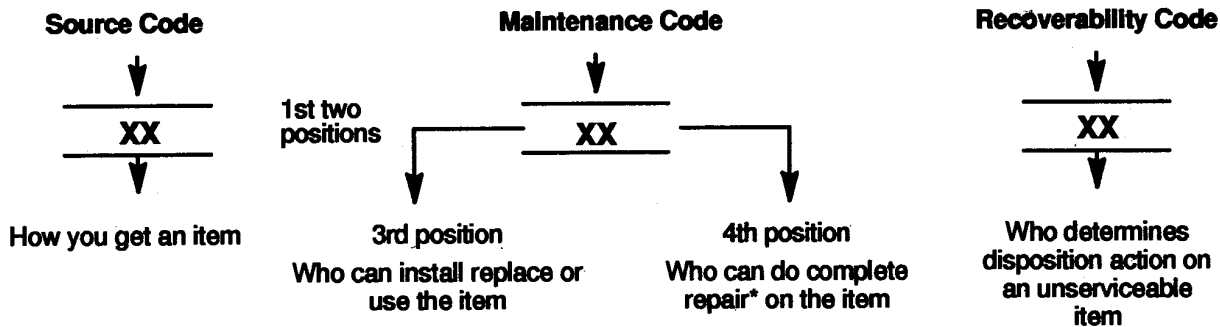

* Complete Rear: Maintenance capacity, capability, and authority to perform all corrective maintenance tasks of the "Repair" function in a use/user environment in order to restore serviceability to a failed item.

(1) Source Code. The source code tells you how you get an item needed for maintenance, repair, or overhaul of an end item/equipment. Explanations of source codes follow.

Source Code	Explanation
PA PB PC** PD PE PF PG	<p>Stocked items; use the applicable NSN to request/requisition items with these source codes. They are authorized to the category indicated by the code entered in the 3rd position of the SMR code.</p> <p>**NOTE : Items coded PC are subject to deterioration.</p>
KD KF KB	<p>Items with these codes are not to be requested/requisitioned individually. They are part of a kit which is authorized to the maintenance category indicated in the 3rd position of the SMR code. The complete kit must be requisitioned and applied.</p>
MO (Made at org AVUM level) MF (Made at DS/AVUM level) MH (Made at GS level) ML (Made at Specialized Repair Activity (SRA)) MD (Made at Depot)	<p>Items with these codes are not to be requested/requisitioned individually. They must be made from bulk material which is identified by the part number in the DESCRIPTION and USABLE ON CODE (UOC) column and listed in the Bulk Material group of the repair parts list in the RPSTL. If the item is authorized to you by the 3rd position code of the SMR code, but the source code indicates it is made at a higher level, order the item from the higher level of maintenance.</p>
AO (Assembled by org AVUM Level) AF (Assembled by DS/AVUM Level) AH (Assembled by GS Category) AL (Assembled by SRA) AD (Assembled by Depot)	<p>Items with these codes are not to be requested/requisitioned individually. The parts that make up the assembled item must be requisitioned or fabricated and assembled at the level of maintenance indicated by the source code. If the 3rd position code of the SMR code, authorizes you to replace the item, but the source code indicates the items are assembled at a higher level, order the item from the higher level of maintenance.</p>
XA - - Do not requisition an "XA"-coded item. Order its next higher assembly. (Also, refer to the NOTE below.) XB - - If an "XB" item is not available from salvage, order it using the CAGE Code and part number given. XC - - Installation drawing, diagram, instruction sheet, field service drawing, that is identified by manufacturer's part number. XD - - Item is not stocked. Order an "XD"-coded item through normal supply channels using the CAGE Code and part number given, if no NSN is available.	

NOTE

Cannibalization or controlled exchange, when authorized, may be used as a source of supply for items with the above source codes, except for those source coded "XA" or those aircraft support items restricted by requirements of AR 750-1

(2) Maintenance Code. Maintenance codes tell you the level(s) of maintenance authorized to USE and REPAIR support items. The maintenance codes are entered in the third and fourth positions of the SMR code as follows:

(a) The maintenance code entered in the third position tells you the lowest maintenance level authorized to remove, replace, and use an item. The maintenance code entered in the third position will indicate authorization to the following levels of maintenance.

Maintenance Code

Application/Explanation

C - Crew or operator maintenance done within unit/AVUM maintenance.

O - Unit level VAVUM maintenance can remove, replace, and use the item.

F - Direct support/AVIM maintenance can remove, replace, and use the item.

H - General support maintenance can remove, replace, and use the item.

L - Specialized repair activity can remove, replace, and use the item.

D - Depot can remove, replace, and use the item.

(b) The maintenance code entered in the fourth position tells whether or not the item is to be repaired and identifies the lowest maintenance level with the capability to do complete repair (i.e., perform all authorized repair functions). This position will contain one of the following maintenance codes.

NOTE

Some limited repair may be done on an item at a lower level of maintenance, if authorized by the Maintenance Allocation Chart (MAC) and SMR codes.

Maintenance Code

Application/Explanation

O - Unit VAVUM is the lowest level that can do complete repair of the item.

F - Direct support VAVIM is the lowest level that can do complete repair of the item.

H - General Support is the lowest level that can do complete repair of the item.

L - Specialized repair activity is the lowest level that can do complete repair of the item.

D - Depot is the lowest level that can do complete repair of the item.

Z - Nonreparable. No repair is authorized.

B - No repair is authorized. No parts or special tools are authorized for the maintenance of a "B" coded item. However, the item may be reconditioned by adjusting, lubricating, etc., at the user level.

(3) Recoverability. Recoverability codes are assigned to items to indicate the disposition action on unserviceable items. The recoverability code is entered in the fifth position of the SMR Code as follows:

**Recoverability
Codes**

Application/Explanation

- Z - Nonreparable item. When unserviceable, condemn and dispose of the item at the level of maintenance shown in 3rd position of SMR Code.
- O - Reparable item. When not economically repairable, condemn and dispose of the item at unit or AVUM level.
- F - Reparable item. When uneconomically repairable, condemn and dispose of the item at the direct support or AVIM level.
- H - Reparable item. When uneconomically repairable, condemn and dispose of the item at the general support level.
- D - Reparable item. When beyond lower level repair capability, return to depot. Condemnation and disposal of item not authorized below depot level.
- L - Reparable item. Condemnation and disposal not authorized below specialized repair activity (SRA).
- A - Item requires special handling or condemnation procedures because of specific reasons (e.g., precious metal content, high dollar value, critical material, or hazardous material). Refer to appropriate manuals/directives for specific instructions.

c. CAGEC (Column (3)). The Commercial and Government Entity Code (CAGEC) is a 5-digit numeric code which is used to identify the manufacturer, distributor, or Government agency/activity that supplies the item.

d. PART NUMBER (Column (4)). Indicates the primary number used by the manufacturer, (individual, company, firm, corporation, or Government activity), which controls the design and characteristics of the item by means of its engineering drawings, specifications, standards, and inspection requirements to identify an item or range of items.

NOTE

When you use an NSN to requisition an item, the item you receive may have a different part number from the number listed.

e. DESCRIPTION AND USABLE ON CODE (UOC) (Column (5)). This column includes the following information:

- (1) The Federal item name and, when required, a minimum description to identify the item.
- (2) Part numbers of bulk materials are referenced in this column in the line entry to be manufactured/fabricated
- (3) The statement "END OF FIGURE" appears just below the last item description in Column (5) for a given figure in both Section II and Section III.

f. QTY (Column (6)). The QTY (quantity per figure) column indicates the quantity of the item used in the breakout shown on the illustration/figure, which is prepared for a functional group, subfunctional group, or an assembly. A "V" appearing in this column instead of a quantity indicates that the quantity is variable and may vary from application to application.

4. EXPLANATION OF INDEX FORMAT AND COLUMNS (SECTION IV)

a. NATIONAL STOCK NUMBER (NSN) INDEX.

(1) STOCK NUMBER Column. This column lists the NSN in national item identification number (NIIN) sequence. The NIIN consists of the last nine digits of the NSN, i.e.

NSN
5305-01-574-1467
NIIN

When using this column to locate an item, ignore the first four digits of the NSN. Use the complete NSN (1 3 digits) when requisitioning items by stock number.

(2) FIG. Column. This column lists the number of the figure where the item is identified/located. The figures are in numerical order in Section II and Section III.

(3) ITEM Column. The item number identifies the item associated with the figure listed in the adjacent FIG. column. This item is also identified by the NSN listed on the same line.

b. PART NUMBER INDEX. Part numbers in this index are listed in ascending alphanumeric sequence (i. e., vertical arrangement of letter and number combinations which place the first letter or digit of each group in order A through Z, followed by the numbers 0 through 9, and each following letter or digit in like order).

(1) CAGEC Column. The Commercial and Government Entity Code (CAGEC) is a 5-digit numeric code used to identify the manufacturer, distributor, or Government agency/activity that supplies the item.

(2) PART NUMBER Column. Indicates the primary number used by the manufacturer (individual, firm, corporation, or Government activity), which controls the design and characteristics of the item by means of its engineering drawings, specifications, standards, and inspection requirements to identify an item or range of items.

(3) STOCK NUMBER Column. This column lists the NSN for the associated part number and manufacturer identified in the PART NUMBER and CAGEC columns to the left.

(4) FIG. Column. This column lists the number of the figure where the item is identified/located in Section II and Section III.

(5) ITEM Column. The item number is that number assigned to the item as it appears in the figure referenced in the adjacent figure number column.

c. FIGURE AND ITEM NUMBER INDEX.

(1) FIG. Column. This column lists the number of the figure where the item is identified/located in Section II and Section III.

(2) ITEM Column. The item number is that number assigned to the item as it appears in the figure referenced in the adjacent figure number column.

(3) STOCK NUMBER Column. This column lists the NSN for the item.

(4) CAGEC Column. The Commercial and Government Entity Code (CAGEC) is a 5-digit numeric code used to identify the manufacturer, distributor, or Government agency/activity that supplies the item.

(5) PART NUMBER Column. Indicates the primary number used by the manufacturer (individual, firm, corporation, or Government activity), which controls the design and characteristics of the item by means of its engineering drawings, specifications, standards, and inspection requirements to identify an item or range of items.

5. SPECIAL INFORMATION.

a. USABLE ON CODE. The usable on code appears in the lower left corner of the Description column heading. Usable on codes are shown as "UOC:.." in the Description Column (justified left) on the last line of the applicable item description/nomenclature. Uncoded items are applicable to all models.

b. FABRICATION INSTRUCTIONS. Bulk materials required to manufacture items are listed in the Bulk Material Functional Group of this RPSTL. Part numbers for bulk materials are also referenced in the description column of the line item entry for the item to be manufactured/fabricated.

c. INDEX NUMBERS. Items which have the word BULK in the figure column will have an index number shown in the item number column. This index number is a cross-reference between the National Stock Number/Part Number Index and the bulk material list in Section II.

e. ASSOCIATED PUBLICATIONS. There are no associated publications

6. HOW TO LOCATE REPAIR PARTS.

a. When National Stock Numbers or Part Numbers are NOT Known.

(1) First. Using the table of contents, determine the assembly or subassembly group to which the item belongs. This is necessary since figures are prepared for assembly groups and subassembly groups, and listings are divided into the same groups.

(2) Second. Find the figure covering the assembly group or subassembly group to which the item belongs.

(3) Third. Identify the item on the figure and use the Figure and Item Number Index to find the NSN.

b. When National Stock Number or Part Number is Known.

(1) First. Using the of National Stock Number and Part Number Indexes find the pertinent National Stock Number or Part Number. The NSN index is in National Item Identification Number (NIIN) sequence (see paragraph 4.a.). The part numbers in the Part Number index are listed in ascending alphanumeric sequence (see paragraph 4.b.). Both indexes cross-reference you to the illustration/figure and item number of the item you are looking for.

(2) Second. Turn to the figure and item number, verify that the item is the one you are looking for, then locate the item number in the repair parts list for the figure.

7. ABBREVIATIONS. Abbreviations used in this manual are listed in MIL-STD-12.

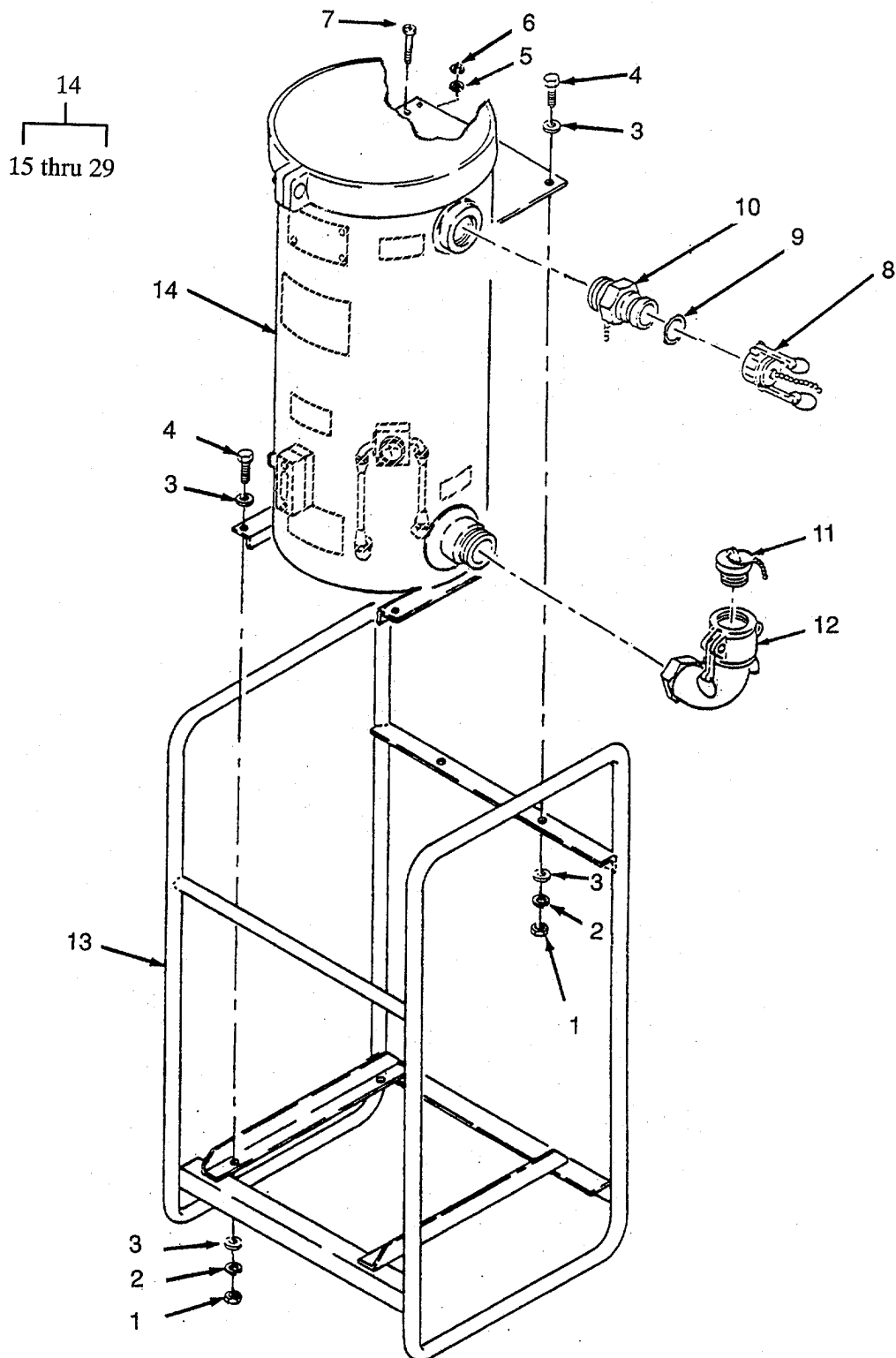

Figure F-1. Tank and Frame Assembly (Sheet 1 of 2)

Change 1

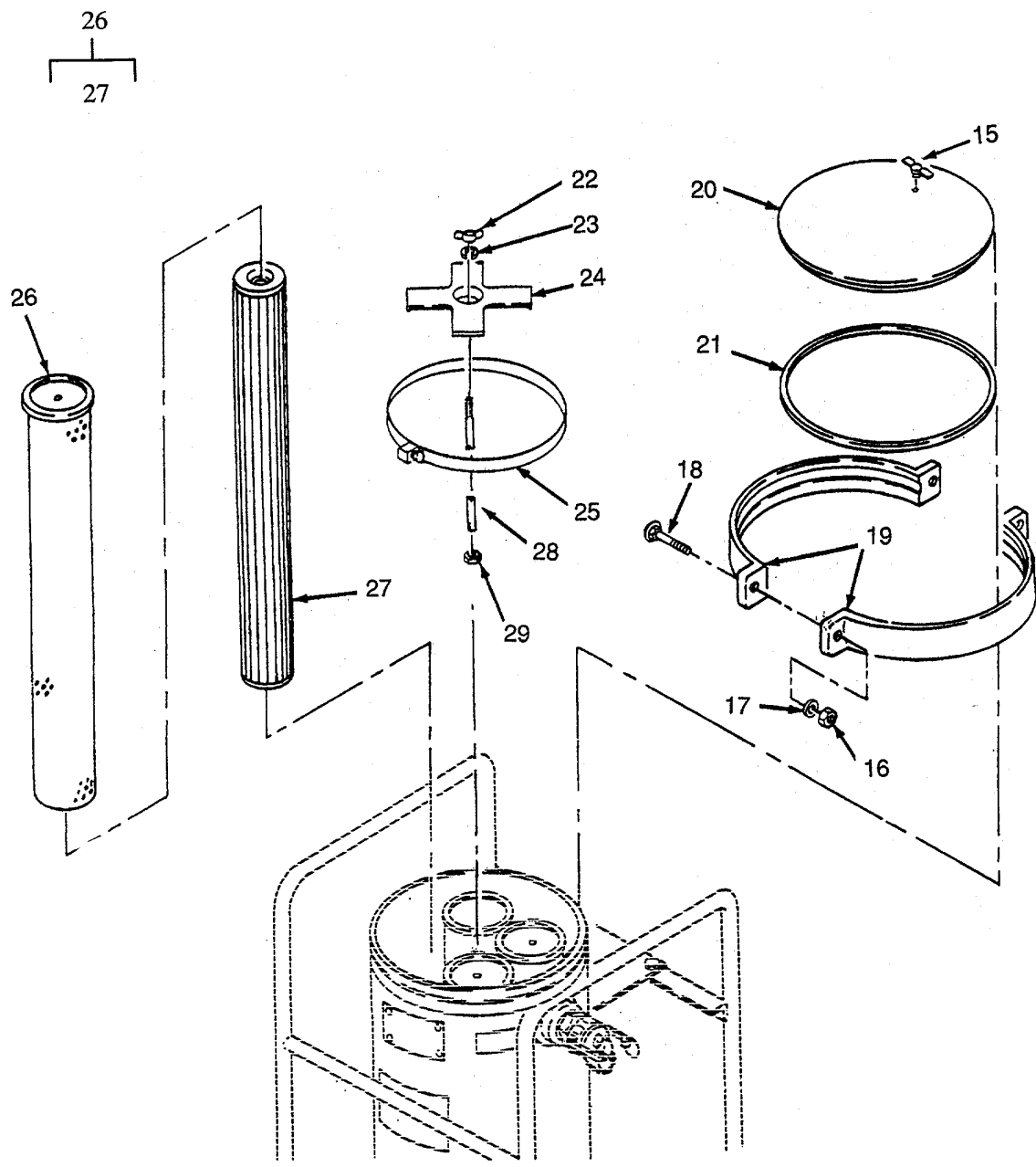

Figure F-1. Tank and Frame Assembly (Sheet 2 of 2)

Change 1

SECTION II

TM 11-5841-285-30P

(1) ITEM NO	(2) SMR CODE	(3) CAGEC	(4) PART NUMBER	(5) DESCRIPTION AND USABLE ON CODES (UOC)	(6) QTY
GROUP 01 TANK AND FRAME ASSEMBLY					
FIG. 1 TANK AND FRAME ASSEMBLY					
1	PAOZZ	96906	MS51967-14	NUT, PLAIN, HEXAGON	6
2	XBOZZ	96906	MS35338-48	WASHER, SPLIT LOCK	6
3	PAOZZ	96906	MS27183-18	WASHER, FLAT	12
4	XBOZZ	96906	MS90725-111	SCREW, CAP, HEX HD.....	6
5	PAOZZ	96906	MS51922-2	NUT, HEX, SELF-LOCK	1
6	PAOZZ	96906	MS35333-74	WASHER, LOCK	1
7	PAOZZ	96906	MS51957-82	SCREW, MACHINE.....	1
8	PAOZZ	96906	MS27028-9	COUPLING HALF, CAP.....	1
9	PAOZZ	96906	MS27030-5	GASKET	2
10	PAOZZ	96906	MS27024-9	COUPLING HALF	1
11	PAOZZ	96906	MS27029-9	COUPLING HALF, PLUG	1
12	PBOZZ	97403	13217E7125	COUPLING HALF, QUICK.....	1
13	XBOZZ	97403	13217E6314	FRAME, TANK.....	1
14	PDOOO	97403	13217E7140	FILTER-SEPARATOR, LI	1
IS	PAOZZ	97403	13216E2789	. VALVE, MANUAL VENT	1
16	PAOZZ	96906	MS51967-20	. NUT, PLAIN, HEXAGON	2
17	PAOZZ	96906	MS27183-21	. WASHER, FLAT	2
18	PAOZZ	96906	MS35751-158	. BOLT, SQ NECK, RD HD	2
19	XBOZZ	97403	13217E6313	. COUPLING, CLAMP, PIPE	1
20	PBOZZ	97403	13217E6312	. COVER, ACCESS	1
21	PAOZZ	97403	13217E6318	. PACKING, PREFORMED	1
22	PAOZZ	96906	MS35425-36	. NUT, PLAIN, WING	1
23	PAOZZ	96906	MS35338-144	. WASHER, LOCK	1
24	XBOZZ	97403	13217E6317	. RETAINER, CANISTER.....	4
25	XBOZZ	97403	13216E2789-4	. CLAMP, BAND	1
26	PBOZZ	97403	13217E6316	. FILTER ELEMENT, CANISTER.....	4
27	PAOZZ	81349	MILF52308	. . FILTER ELEMENT, FLUI.....	4
28	PBOZZ	97403	13217E6315	. ROD, THREADED END.....	1
29	PAOZZ	96906	MS51971-5	. NUT, PLAIN, HEXAGON	1

END OF FIGURE

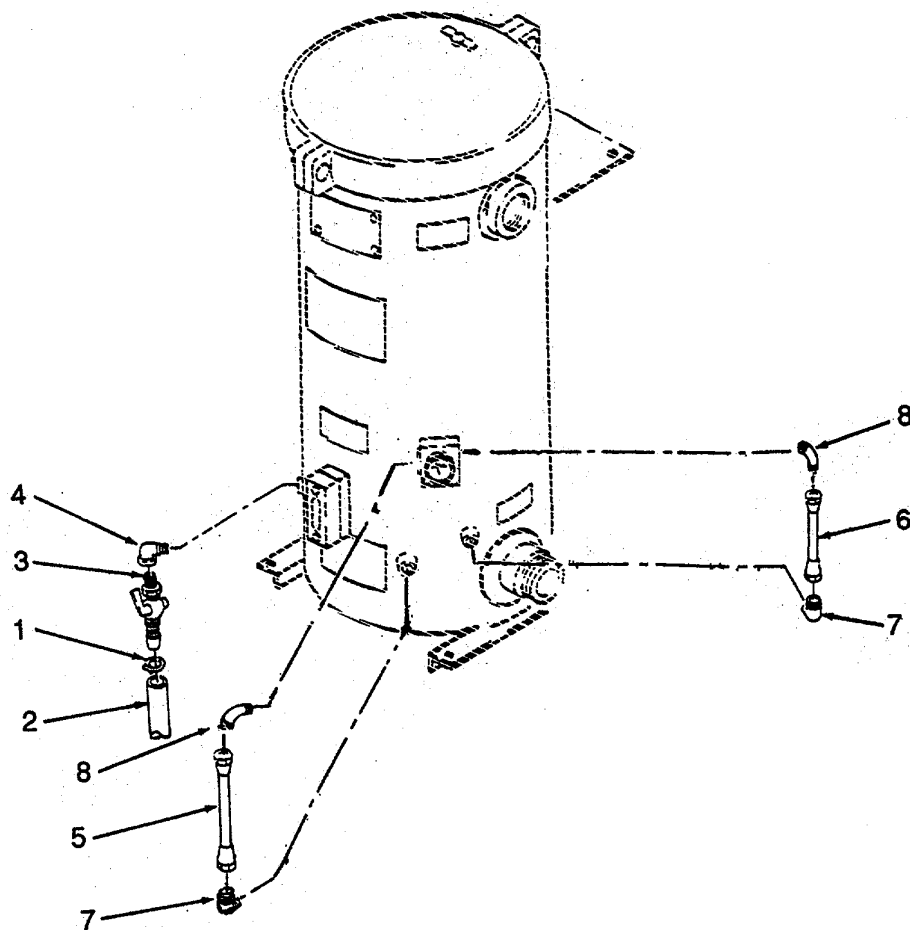

Figure F-2. Valves, Lines and Fittings

Change 1

SECTION II

TM 11-5841-285-30P

(1) ITEM NO	(2) SMR CODE	(3) CAGEC	(4) PART NUMBER	(5) DESCRIPTION AND USABLE ON CODES (UOC)	(6) QTY
-------------------	--------------------	--------------	-----------------------	--	------------

GROUP 02 VALVES, LINES AND FITTINGS

FIG. 2 VALVES, LINES AND FITTINGS

1	PAOZZ	96906	MS35842-10	. CLAMP, HOSE	1
2	PAOZZ	00624	1525-6	. HOSE, NONMETALLIC	3
3	PBOZZ	97403	13217E6309	. COCK, DRAIN	1
4	XBOZZ	97403	13218E0114-15	. ELBOW, PIPE WATER DRAIN COCK MTG.....	2
				90 DEG CAST BRS, 1/2-14 NPTF EXT X 1/2	
				14 NPTF INT	
5	PAOZZ	97403	13217E5365-1	. TUBE ASSEMBLY, METAL	1
6	XDOZZ	97403	13217E5365-7	. TUBE ASSEMBLY, METAL	1
7	PAOZZ	96906	MS20822-5-4D	. ELBOW, PIPE TO TUBE	2
8	PAOZZ	96906	MS20822-5D	. ELBOW, PIPE TO TUBE	2

END OF FIGURE

Change 1 F-2-1

1
┌───┴───┐
2 thru 7

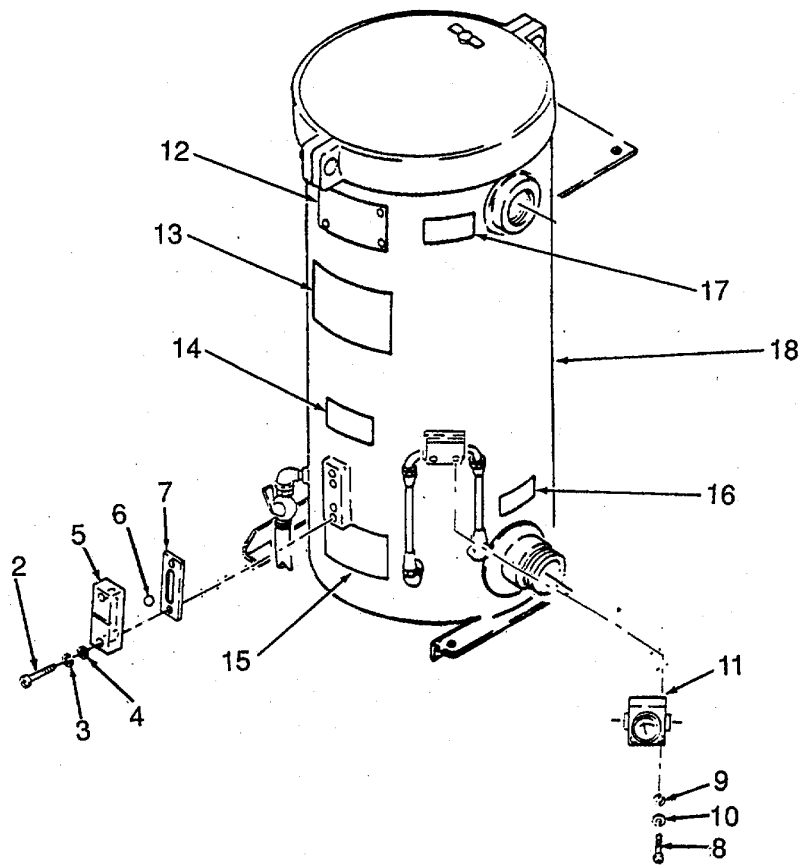

Figure F-3. Sight Gauge and Differential Pressure Gauge

Change 1

(1) ITEM NO	(2) SMR CODE	(3) CAGEC	(4) PART NUMBER	(5) DESCRIPTION AND USABLE ON CODES (UOC)	(6) QTY
GROUP 03 SIGHT GAUGE AND DIFFERENTIAL PRESSURE GAUGE					
FIG. 3 SIGHT GAUGE AND DIFFERENTIAL GAUGE					
1	PAOZO	97403	13217E5360	. GLASS, LIQUID SIGHT	1
2	PAOZZ	96906	MS51957-84	. . SCREW, MACHINE	2
3	PAOZZ	96906	MS35338-44	. . WASHER, LOCK	2
4	PAOZZ	96906	MS15795-810	. . WASHER, FLAT	2
5	XAOZZ	97403	13217E5361	. . INDICATOR, SIGHT, LIQ	1
6	XAOZO	97403	13217E5362	. . FLOAT, SIGHT INDICAT	1
7	XAOZO	97403	13217E5363	. . GASKET	1
8	PAOZZ	96906	MS35207-269	. SCREW, MACHINE	2
9	PAOZZ	96906	MS35338-44	. WASHER, LOCK	2
10	PAOZZ	96906	MS27183-50	. WASHER, FLAT	2
11	PAOZO	97403	13219E9749-1	. GAUGE, DIFFERENTIAL, D	1
12	XBOZZ	97403	13217E6308	. PLATE	1
13	XBOZZ	97403	13219E5358	. PLATE, WARNING	1
14	XBOZZ	97403	13219E9751	. PLATE, IDENTIFICATION	1
15	XBOZZ	97403	13216E2768	. PLATE, INSTRUCTION	1
16	XBOZZ	97403	13216E2767	. PLATE, INSTRUCTION	1
17	XBOZZ	97403	13216E2766	. PLATE, INSTRUCTION	1
18	XAOZZ	97403	13217E6311	. TANK, FILTER SEPARAT	1

END OF FIGURE

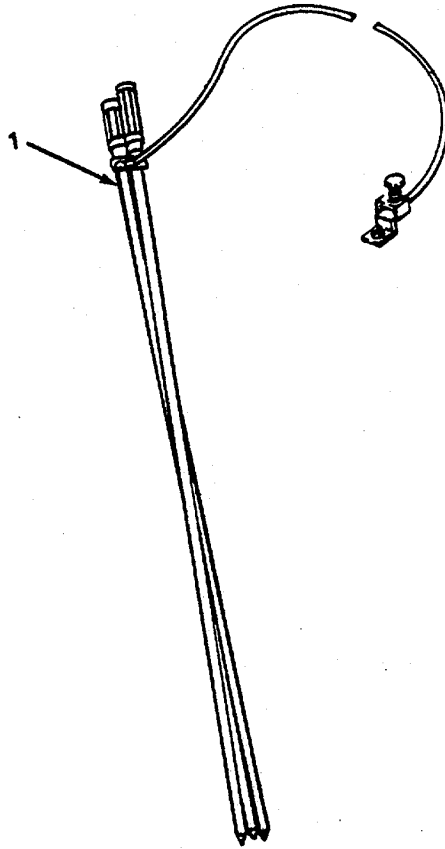

Figure F-4. Grounding Rod Assembly

Change 1

SECTION II

TM 11-5841-285-30P

(1) ITEM NO	(2) SMR CODE	(3) CAGEC	(4) PART NUMBER	(5) DESCRIPTION AND USABLE ON CODES (UOC)	(6) QTY
GROUP 04 GROUNDING ROD ASSEMBLY					
FIG. 4 GROUNDING ROD ASSEMBLY					
1	PAOZZ	81349	MILR11461	GROUNDING ROD ASSY	1
END OF FIGURE					

1
┌───┐
│ │
└───┘
2 thru 8

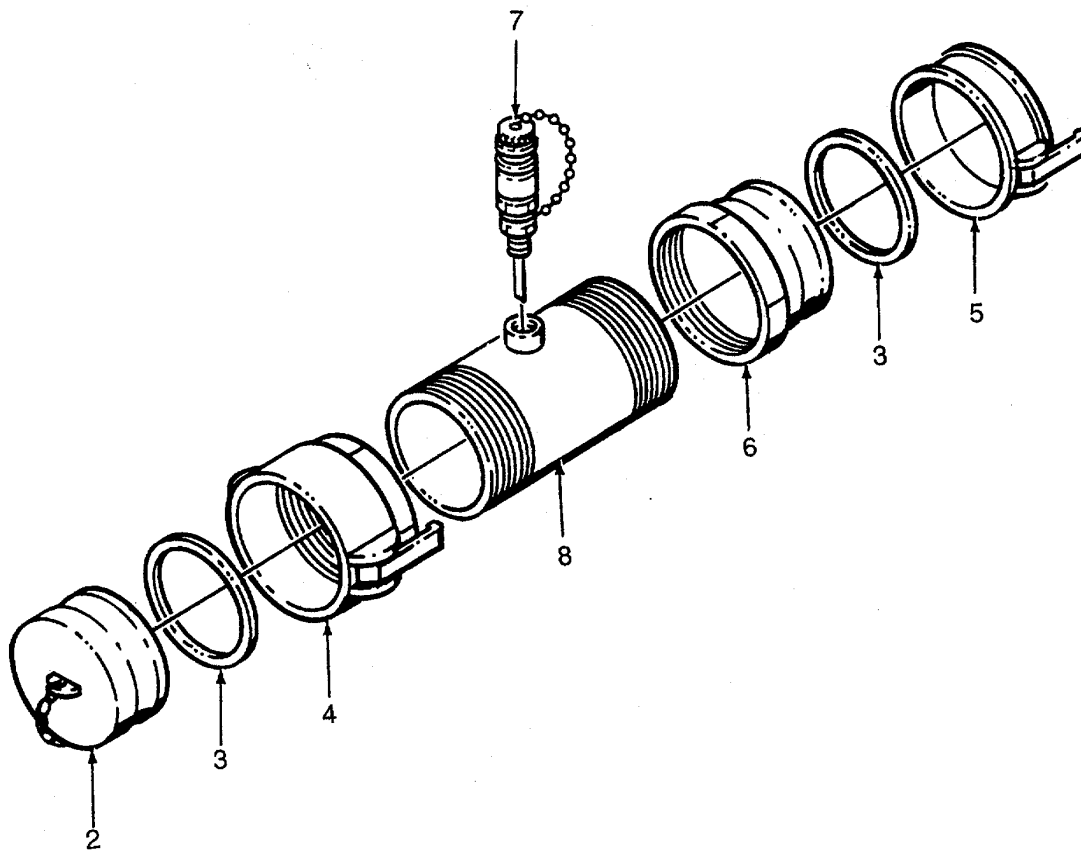

Figure F-5. Water Detector Kit

Change 1

SECTION II

TM 11-5841-285-30P

(1) ITEM NO	(2) SMR CODE	(3) CAGEC	(4) PART NUMBER	(5) DESCRIPTION AND USABLE ON CODES (UOC) GROUP 05 WATER DETECTOR KIT	(6) QTY
FIG. 5 WATER DETECTOR KIT					
1	PBOOZ	97403	13220E9406-3	. ADAPTER, ASSEMBLY, WA.....	1
2	XBOZZ	96906	MS27029-9	. . PLUG, QUICK DISCONNE	1
3	PAOZO	96906	MS27030-5	. . GASKET	2
4	PAOZO	96906	MS27024-9	. . COUPLING HALF, QUICK.....	1
5	PAOZO	96906	MS27028-9	. . CAP, QUICK DISCONNEC	1
6	PAOZO	96906	MSZ7020-9	. . COUPLING HALF, QUICK.....	1
7	PAOZZ	97403	13220E9914-3	. . PROBE ASSY, WATER DE	1
8	XAOZZ	97403	13220E9406-3-4/5	. . ADAPTER, PIPE.....	1

END OF FIGURE

APPENDIX G

ILLUSTRATED LIST OF MANUFACTURED ITEMS

This index includes complete instructions for making items authorized to be manufactured or fabricated at unit level maintenance.

A Part number index in alphanumeric order is provided for cross-referencing the Part number of the item to be manufactured to the figure which covers fabrication criteria.

All bulk material needed for manufacture of an item are listed by Part number of specification number in a tabular list on the illustration.

<u>Item</u>	INDEX	<u>Figure</u>
Drain Hose		G-1

Parts needed: Hose (P/N FS0216B121-1 (1527)

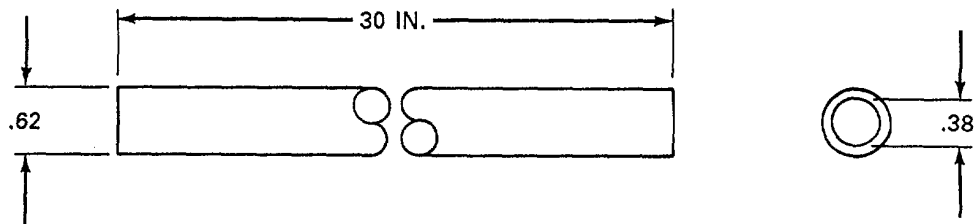

Figure G-1. Drain Hose.

NOTES

- (1) All dimensions in inches.
- (2) Cut hose to length.

G-1/(G-2 blank)

SECTION III

TM 10-4330-232-12&P

SPECIAL TOOLS

NOT APPLICABLE

Change 1

CROSS-REFERENCE INDEXES

NATIONAL STOCK NUMBER INDEX

STOCK NUMBER	FIG.	ITEM	STOCK NUMBER	FIG.	ITEM
5305-00-071-1317	F-1	7			
5305-00-071-2087	F-3	2			
4330-00-072-6700	F-1	26			
4820-00-134-8248	F-2	3			
5330-00-171-4827	F-1	21			
4710-00-186-3189	F-2	5			
6680-00-197-4941	F-3	1			
5310-00-274-9337	F-1	22			
4730-00-278-3678	F-2	8			
4730-00-278-4684	F-2	7			
5310-00-285-8124	F-3	9			
5330-00-360-0595	F-1	9			
	F-4	3			
5340-00-451-8058	F-1	20			
5306-00-476-7559	F-1	28			
5310-00-543-2740	F-1	6			
5310-00-582-5965	F-3	8			
4730-00-735-4388	F-1	12			
5310-00-763-8920	F-1	16			
5310-00-768-0318	F-1	1			
5310-00-768-0321	F-1	29			
5310-00-809-5998	F-1	3			
4730-00-823-5316	F-1	11			
5310-00-823-8803	F-1	17			
4730-00-869-5246	F-1	8			
	F-4	5			
4730-00-908-3195	F-2	1			
5310-00-926-5870	F-1	23			
5310-00-929-1807	F-1	5			
4730-00-948-1719	F-4	6			
4730-00-980-9411	F-1	10			
	F-4	4			
4330-00-983-0998	F-1	27			
5305-00-995-3441	F-3	7			
5306-01-009-7166	F-1	18			
4330-01-012-3313	F-1	14			
6685-01-015-8645	F-3	10			
5310-01-091-1248	F-3	3			
4930-01-159-4437	F-4	1			
4930-01-169-5287	F-4	7			

CROSS-REFERENCE INDEXES

CAGEC	PART NUMBER	PART NUMBER INDEX		FIG.	ITEM
			STOCK NUMBER		
81349	MILF52308		4330-00-983-0998	F-1	27
81349	MILR11461			F-4	1
96906	MS15795-810		5310-01-091-1248	F-3	3
96906	MS20822-5-4D		4730-00-278-4684	F-2	7
96906	MS20822-5D		4730-00-278-3678	F-2	8
96906	MS27020-9		4730-00-948-1719	F-4	6
96906	MS27024-9		4730-00-980-9411	F-1	10
				F-4	4
96906	MS27028-9		4730-00-869-5246	F-1	8
				F-4	5
96906	MS27029-9		4730-00-823-5316	F-1	11
				F-4	2
96906	MS27030-5		5330-00-360-0595	F-1	9
				F-4	3
96906	MS27183-18		5310-00-809-5998	F-1	3
96906	MS27183-21		5310-00-823-8803	F-1	17
96906	MS27183-50		5310-00-285-8124	F-3	9
96906	MS35207-269		5305-00-995-3441	F-3	7
96906	MS35333-74		5310-00-543-2740	F-1	6
96906	MS35338-144		5310-00-926-5870	F-1	23
96906	MS35338-44		5310-00-582-5965	F-3	8
96906	MS35338-48			F-1	2
96906	MS35425-36		5310-00-274-9337	F-1	22
96906	MS35751-158		5306-01-009-7166	F-1	18
96906	MS35842-10		4730-00-908-3195	F-2	1
96906	MS51922-2		5310-00-929-1807	F-1	5
96906	MS51957-82		5305-00-071-1317	F-1	7
96906	MS51957-84		5305-00-071-2087	F-3	2
96906	MS51967-14		5310-00-768-0318	F-1	1
96906	MS51967-20		5310-00-763-8920	F-1	16
96906	MS51971-5		5310-00-768-0321	F-1	29
96906	MS90725-111			F-1	4
97403	13216E2766			F-3	16
97403	13216E2767			F-3	15
97403	13216E2768			F-3	14
97403	13216E2789			F-1	15
97403	13216E2789-4			F-1	25
97403	13217E5358			F-3	12
97403	13217E5360		6680-00-197-4941	F-3	1
97403'	13217E5361			F-3	4
97403	13217E5362			F-3	5
97403	13217E5363			F-3	6
97403	13217E5365-1		4710-00-186-3189	F-2	5
97403	13217E5365-7			F-2	6
97403	13217E6308			F-3	11
97403	13217E6309		4820-00-134-8248	F-2	3
97603	13217E6311			F-3	17
97403	13217E6312		5340-00-451-8058	F-1	20
97403	13217E6313			F-1	19
97403	13217E6314			F-1	13
97403	13217E6315		5306-U0-476-7559	F-1	28

**CROSS-REFERENCE INDEXES
PART NUMBER INDEX**

CAGEC	PART NUMBER	STOCK NUMBER	FIG.	ITEM
97403	13217E6316	4330-00-072-6700	F-1	26
97403	13217E6317		F-1	24
97403	13217E6318	5330-00-171-4827	F-1	21
97403	13217E7125	4730-00-735-4388	F-1	12
97403	13217E7140	4330-01-012-3313	F-1	14
97403	13218E0114-15		F-2	4
97403	13219E9749-1	6685-01-015-8645	F-3	10
97403	13219E9751		F-3	13
97403	13220E9406-3	4930-01-159-4437	F-4	1
97403	13220E9406-3-4/5		F-4	8
97403	13220E9914-3	4930-01-169-5287	F-4	7
00624	1525-6		F-2	2

CROSS-REFERENCE INDEXES

FIG.	ITEM	FIGURE AND ITEM NUMBER INDEX		PART NUMBER
		STOCK NUMBER	CAGEC	
F-1	1	5310-00-768-0318	96906	MS51967-14
F-1	2		96906	MS35338-48
F-1	3	5310-00-809-5998	96906	MS27183-18
F-1	4		96906	MS90725-111
F-1	5	5310-00-929-1807	96906	MS51922-2
F-1	6	5310-00-543-2740	96906	MS35333-74
F-1	7	5305-00-071-1317	96906	MS51957-32
F-1	8	4730-00-869-5246	96906	MS27028-9
F-1	9	5330-00-360-0595	96906	MS27030-5
F-1	10	4730-00-980-9411	96906	MS27024-9
F-1	11	4730-00-823-5316	96906	MS27029-9
F-1	12	4730-00-735-4388	97403	13217E7125
F-1	13		97403	13217E6314
F-1	14	4330-01-012-3313	97403	13217E7140
F-1	15		97403	13216E2789
F-1	16	5310-00-763-8920	96906	MS51967-20
F-1	17	5310-00-823-8803	96906	MS27183-21
F-1	18	5306-01-009-7166	96906	MS35751-158
F-1	19		97403	13217E6313
F-1	20	5340-00-451-8058	97403	13217E6312
F-1	21	5330-00-171-4827	97403	13217E6318
F-1	22	5310-00-274-9337	96906	MS35425-36
F-1	23	5310-00-926-5870	96906	MS35338-144
F-1	24		97403	13217E6317
F-1	25		97403	13216E2789-4
F-1	26	4330-00-072-6700	97403	13217E6316
F-1	27	4330-00-983-0998	81349	MILF52308
F-1	28	5306-00-476-7559	97403	13217E6315
F-1	29	5310-00-768-0321	96906	MS51971-5
F-2	1	4730-00-908-3195	96906	MS35842-10
F-2	2		00624	1525-6
F-2	3	4820-00-134-8248	97403	13217E6309
F-2	4		97403	13218E0114-15
F-2	5	4710-00-186-3189	97403	13217E5365-1
F-2	6		97403	13217E5365-7
F-2	7	4730-00-278-4684	96906	MS20822-5-4D
F-2	8	4730-00-278-3678	96906	MS20822-5D
F-3	1	6680-00-197-4941	97403	13217E5360
F-3	2	5305-00-071-2087	96906	MS51957-84
F-3	3	5310-01-091-1248	96906	MS15795-810
F-3	4		97403	13217E5361
F-3	5		97403	13217E5362
F-3	6		97403	13217E5363
F-3	7	5305-00-995-3441	96906	MS35207-269
F-3	8	5310-00-582-5965	96906	MS35338-44
F-3	9	5310-00-285-8124	96906	MS27183-50
F-3	10	6685-01-015-8645	97403	13219E9749-1
F-3	11		97403	13217E6308
F-3	12		97403	13217E5358
F-3	13		97403	13219E9751
F-3	14		97403	13216E2768

**CROSS-REFERENCE INDEXES
FIGURE AND ITEM NUMBER INDEX**

FIG.	ITEM	STOCK NUMBER	CAGEC	PART NUMBER
F-3	15		97403	13216E2767
F-3	16		97403	13216E2766
F-3	17		97403	13217E6311
F-4	1		81349	MILR11461
F-4	1	4930-01-159-4437	97403	13220E9406-3
F-4	2		96906	MS27029-9
F-4	3	5330-00-360-0595	96906	MS27030-5
F-4	4	4730-00-980-9411	96906	MS27024-9
F-4	5	4730-00-869-5246	96906	MS27028-9
F-4	6	4730-00-948-1719	96906	MS27020-9
F-4	7	4930-01-169-5287	97403	13220E9914-3
F-4	8		97403	13220E9406-3-4/5

INDEX

Subject	Paragraph
A	
Administrative Storage.....	4-25
Appendices:	
A-References.....	A-1
B-Maintenance Allocation Chart.....	B-1
C-Components of End Item and Basic Issue Items.....	C-1
D-Additional Authorization List.....	D-1
E-Expendable/Durable Supplies and Material List.....	E-1
F-Repair Parts and Special Tools List.....	F-1
G-Illustrated List of Manufactured Items.....	G-1
Assembly, Grounding Rod.....	4-22
B	
C	
Canisters.....	4-17
Coupling Gasket.....	4-14
Cover.....	4-12
D	
Description and Use of Operator's Controls and Indicators.....	2-2
Destruction of Army Material to Prevent Enemy Use.....	1-4
Differences Between Models.....	1-10
Differential Pressure Indicator.....	4-21
E	
Elements.....	4-18
Equipment Characteristics, Capabilities and Features.....	1-7
Equipment Data.....	1-9
F	
Frame.....	4-16
G	
Gauge, Sight.....	4-20
Gasket, Coupling.....	4-14
Grounding Rod Assembly.....	4-22
H	

INDEX (Cont)

Subject	Paragraph
Inspection	4-6
Installation.....	4-7
J, K	
L	
Location and Description of Major Components.....	1-8
M	
Maintenance Forms, Records and Reports.....	1-2
Maintenance, Unit	
Canister	4-17
Coupling Gasket	4-14
Cover.....	4-12
Differential Pressure Indicator	4-21
Elements	4-18
Frame.....	4-16
Manual Vent Valve.....	4-13
Sight Gauge.....	4-20
Tank	4-15
Valves, Lines, and Fittings	4-19
N	
O	
Operating.....	2-10
Operation at High Altitudes	2-17
Operation in Dusty or Sandy Areas	2-14
Operation in Extreme Cold.....	2-12
Operation in Extreme Heat.....	2-13
Operation in Rainy or Humid Conditions.....	2-15
Operation in Salt Water Areas.....	2-16
Operators Controls and Indicators	2-2
P	
Preparation for Storage or Shipment.....	1-5
Preventive Maintenance Checks and Services	
Operator	2-3
Unit.....	4-9
Principles of Operation.....	1-12

INDEX (Cont)

Subject Paragraph

Q

R

Repair Parts; Special Tools; and Support Equipment 4-2, 4-3
 Reporting Equipment Improvement Recommendations (EIR)..... 1-3

S

Safety, Care and Handling1-10
 Service Upon Receipt 4-4
 Sight Gauge.....4-20
 Starting Procedure 2-9
 Stopping Procedure.....2-11

T

Tank.....4-15
 Troubleshooting Procedures
 Operator 3-3
 Unit.....4-11

U

Unit Maintenance
 Canister4-17
 Coupling Gasket4-14
 Cover.....4-12
 Differential Pressure Indicator4-21
 Elements4-18
 Frame.....4-16
 Manual Vent Valve.....4-13
 Sight Gauge.....4-20
 Tank4-15
 Valves, Lines, and Fittings4-19
 Unit Preventive Maintenance Checks and Services (PMCS) 4-9
 Unit Troubleshooting4-11
 Unloading..... 4-4
 Unpacking..... 4-5

V

Valve, Lines, and Fittings.....4-19
 Vent Valve, Manual.....4-13

W, X, Y, Z

By Order of the Secretary of the Army:

GORDON R. SULLIVAN
General, United States Army
Chief of Staff

Official:

PATRICIA P. HICKERSON
Brigadier General, United States Army
The Adjutant General

DISTRIBUTION:

To be distributed in accordance with DA Form 12-25E (qty rqr block no. 0790)

RECOMMENDED CHANGES TO EQUIPMENT TECHNICAL PUBLICATIONS



THEN...JOT DOWN THE DOPE ABOUT IT ON THIS FORM. CAREFULLY TEAR IT OUT, FOLD IT AND DROP IT IN THE MAIL.

SOMETHING WRONG WITH PUBLICATION

FROM: (PRINT YOUR UNIT'S COMPLETE ADDRESS)

DATE SENT

PUBLICATION NUMBER

PUBLICATION DATE

PUBLICATION TITLE

BE EXACT PIN-POINT WHERE IT IS

PAGE NO.

PARA-GRAPH

FIGURE NO.

TABLE NO.

IN THIS SPACE, TELL WHAT IS WRONG AND WHAT SHOULD BE DONE ABOUT IT.

TEAR ALONG PERFORATED LINE

PRINTED NAME, GRADE OR TITLE AND TELEPHONE NUMBER

SIGN HERE

The Metric System and Equivalents

Linear Measure

1 centimeter = 10 millimeters = .39 inch
 1 decimeter = 10 centimeters = 3.94 inches
 1 meter = 10 decimeters = 39.37 inches
 1 dekameter = 10 meters = 32.8 feet
 1 hectometer = 10 dekameters = 328.08 feet
 1 kilometer = 10 hectometers = 3,280.8 feet

Weights

1 centigram = 10 milligrams = .15 grain
 1 decigram = 10 centigrams = 1.54 grains
 1 gram = 10 decigrams = .035 ounce
 1 dekagram = 10 grams = .35 ounce
 1 hectogram = 10 dekagrams = 3.52 ounces
 1 kilogram = 10 hectograms = 2.2 pounds
 1 quintal = 100 kilograms = 220.46 pounds
 1 metric ton = 10 quintals = 1.1 short tons

Liquid Measure

1 centiliter = 10 milliliters = .34 fl. ounce
 1 deciliter = 10 centiliters = 3.38 fl. ounces
 1 liter = 10 deciliters = 33.81 fl. ounces
 1 dekaliter = 10 liters = 2.64 gallons
 1 hectoliter = 10 dekaliters = 26.42 gallons
 1 kiloliter = 10 hectoliters = 264.18 gallons

Square Measure

1 sq. centimeter = 100 sq. millimeters = .155 sq. inch
 1 sq. decimeter = 100 sq. centimeters = 15.5 sq. inches
 1 sq. meter (centare) = 100 sq. decimeters = 10.76 sq. feet
 1 sq. dekameter (are) = 100 sq. meters = 1,076.4 sq. feet
 1 sq. hectometer (hectare) = 100 sq. dekameters = 2.47 acres
 1 sq. kilometer = 100 sq. hectometers = .386 sq. mile

Cubic Measure

1 cu. centimeter = 1000 cu. millimeters = .06 cu. inch
 1 cu. decimeter = 1000 cu. centimeters = 61.02 cu. inches
 1 cu. meter = 1000 cu. decimeters = 35.31 cu. feet

Approximate Conversion Factors

To change	To	Multiply by	To change	To	Multiply by
inches	centimeters	2.540	ounce-inches	newton-meters	.007062
feet	meters	.305	centimeters	inches	.394
yards	meters	.914	meters	feet	3.280
miles	kilometers	1.609	meters	yards	1.094
square inches	square centimeters	6.451	kilometers	miles	.621
square feet	square meters	.093	square centimeters	square inches	.155
square yards	square meters	.836	square meters	square feet	10.764
square miles	square kilometers	2.590	square meters	square yards	1.196
acres	square hectometers	.405	square kilometers	square miles	.386
cubic feet	cubic meters	.028	square hectometers	acres	2.471
cubic yards	cubic meters	.765	cubic meters	cubic feet	35.315
fluid ounces	milliliters	29.573	cubic meters	cubic yards	1.308
pints	liters	.473	milliliters	fluid ounces	.034
quarts	liters	.946	liters	pints	2.113
gallons	liters	3.785	liters	quarts	1.057
ounces	grams	28.349	liters	gallons	.264
pounds	kilograms	.454	grams	ounces	.035
short tons	metric tons	.907	kilograms	pounds	2.205
pound-feet	newton-meters	1.356	metric tons	short tons	1.102
pound-inches	newton-meters	.11296			

Temperature (Exact)

°F	Fahrenheit temperature	5/9 (after subtracting 32)	Celsius temperature	°C
----	------------------------	----------------------------	---------------------	----

